

Airwell

Service Manual

HKD DCI Series

Indoor Units		Outdoor Units	
AWSI-HKD009-N11	7SP023054	AWAU-YKD009-H11	7SP062910
AWSI-HKD012-N11	7SP023055	AWAU-YKD012-H11	7SP062911
AWSI-HKD018-N11	7SP023056	AWAU-YKD018-H11	7SP062912
AWSI-HKD024-N11	7SP023057	AWAU-YKD024-H11	7SP062913



REFRIGERANT

R410A

SM HKD DCI 1 GB

HEATPUMP

JULY- 2017

CONTENTS

1. Precaution	3
1.1 Safety Precaution.....	3
1.2 Warning.....	3
2. Function	6
3. Specification	7
4. Dimension	11
4.1 Indoor Unit.....	11
4.2 Outdoor Unit.....	14
5. Refrigerant Cycle Diagram	16
6. Wiring Diagram	17
7. Installation Details	21
7.1 Wrench torque sheet for installation.....	21
7.2 Connecting the cables.....	21
7.3 Pipe length and the elevation.....	22
7.4 Installation for the first time.....	23
7.5 Adding the refrigerant after running the system for many years.....	24
7.6 Re-installation while the indoor unit need to be repaired.....	24
7.7 Re-installation while the outdoor unit need to be repaired.....	25
8. Operation Characteristics	27
9. Electronic function	28
9.1 Abbreviation.....	28
9.2 Display function.....	28
9.3 Main Protection.....	29
9.4 Operation Modes and Functions.....	30
10. Troubleshooting	36
10.1 Indoor Unit Error Display.....	37
10.2 Trouble shooting.....	38
11. Exploded View and Spare Part List	54

1. Precaution

1.1 Safety Precaution

- To prevent injury to the user or other people and property damage, the following instructions must be followed.
- Incorrect operation due to ignoring instruction will cause harm or damage.
- Before service the unit, be sure to read this service manual at first.

1.2 Warning

➤ Installation

- Do not use a defective or underrated circuit breaker. Use this appliance on a dedicated circuit.

There is risk of fire or electric shock.

- For electrical work, contact the dealer, seller, a qualified electrician, or an authorized service center.

Do not disassemble or repair the product, there is risk of fire or electric shock.

- Always ground the product.

There is risk of fire or electric shock.

- Install the panel and the cover of control box securely.

There is risk of fire of electric shock.

- Always install a dedicated circuit and breaker.

Improper wiring or installation may cause fore or electric shock.

- Use the correctly rated breaker of fuse.

There is risk of fire or electric shock.

- Do not modify or extend the power cable.

There is risk of fire or electric shock.

- Do not install, remove, or reinstall the unit by yourself (customer).

There is risk of fire, electric shock, explosion, or injury.

- Be caution when unpacking and installing the product.

Sharp edges could cause injury, be especially careful of the case edges and the

fins on the condenser and evaporator.

- For installation, always contact the dealer or an authorized service center.

- Do not install the product on a defective installation stand.

- Be sure the installation area does not deteriorate with age.

If the base collapses, the air conditioner could fall with it, causing property damage, product failure, and personal injury.

- Do not let the air conditioner run for a long time when the humidity is very high and a door or a window is left open.

- Take care to ensure that power cable could not be pulled out or damaged during operation.

There is risk of fire or electric shock.

- Do not place anything on the power cable.

There is risk of fire or electric shock.

- Do not plug or unplug the power supply plug during operation.

There is risk of fire or electric shock.

- Do not touch (operation) the product with wet hands.

- Do not place a heater or other appliance near the power cable.

There is risk of fire and electric shock.

- Do not allow water to run into electrical parts.

It may cause fire, failure of the product, or electric shock.

- Do not store or use flammable gas or combustible near the product.

There is risk of fire or failure of product.

- Do not use the product in a tightly closed space for a long time.

Oxygen deficiency could occur.

- When flammable gas leaks, turn off the gas and open a window for ventilation before turn the product on.

- If strange sounds or smoke comes from product, turn the breaker off or disconnect the power supply cable.

There is risk of electric shock or fire.

- **Stop operation and close the window in storm or hurricane. If possible, remove the product from the window before the hurricane arrives.**

There is risk of property damage, failure of product, or electric shock.

- **Do not open the inlet grill of the product during operation. (Do not touch the electrostatic filter, if the unit is so equipped.)**

There is risk of physical injury, electric shock, or product failure.

- **When the product is soaked, contact an authorized service center.**

There is risk of fire or electric shock.

- **Be caution that water could not enter the product.**

There is risk of fire, electric shock, or product damage.

- **Ventilate the product from time to time when operating it together with a stove etc.**

There is risk of fire or electric shock.

- **Turn the main power off when cleaning or maintaining the product.**

There is risk of electric shock.

- **When the product is not be used for a long time, disconnect the power supply plug or turn off the breaker.**

There is risk of product damage or failure, or unintended operation.

- **Take care to ensure that nobody could step on or fall onto the outdoor unit.**

This could result in personal injury and product damage.

➤ CAUTION

- **Always check for gas (refrigerant) leakage after installation or repair of product.**

Low refrigerant levels may cause failure of product.

- **Install the drain hose to ensure that water is drained away properly.**

A bad connection may cause water leakage.

- **Keep level even when installing the product.**

It can avoid vibration of water leakage.

- **Do not install the product where the noise or hot air from the outdoor unit could damage the neighborhoods.**

It may cause a problem for your neighbors.

- **Use two or more people to lift and transport the product.**

- **Do not install the product where it will be exposed to sea wind (salt spray) directly.**

It may cause corrosion on the product.

Corrosion, particularly on the condenser and evaporator fins, could cause product malfunction or inefficient operation.

➤ Operational

- **Do not expose the skin directly to cool air for long time. (Do not sit in the draft).**

- **Do not use the product for special purposes, such as preserving foods, works of art etc. It is a consumer air conditioner, not a precision refrigerant system.**

There is risk of damage or loss of property.

- **Do not block the inlet or outlet of air flow.**

- **Use a soft cloth to clean. Do not use harsh detergents, solvents, etc.**

There is risk of fire, electric shock, or damage to the plastic parts of the product.

- **Do not touch the metal parts of the product when removing the air filter. They are very sharp.**

- **Do not step on or put anything on the product. (outdoor units)**

- **Always insert the filter securely. Clean the filter every two weeks or more often if necessary.**

A dirty filter reduces the efficiency of the air conditioner and could cause product malfunction or damage.

- **Do not insert hands or other objects through air inlet or outlet while the product**

PRECAUTION

is operated.

■ **Do not drink the water drained from the product.**

■ **Use a firm stool or ladder when cleaning or maintaining the product.**

Be careful and avoid personal injury.

■ **Replace the all batteries in the remote control with new ones of the same type. Do not mix old and new batteries or different types of batteries.**

There is risk of fire or explosion.

■ **Do not recharge or disassemble the batteries. Do not dispose of batteries in a fire.**

They may burn or explode.

■ **If the liquid from the batteries gets onto your skin or clothes, wash it well with clean water. Do not use the remote if the batteries have leaked.**

2. Function

Model Names of Indoor/Outdoor Units

	Capacity	Indoor units	Outdoor units
3D Inverter	9K	AWSI-HKD009-N11	AWAU-YKD009-H11
	12K	AWSI-HKD012-N11	AWAU-YKD012-H11
	18K	AWSI-HKD018-N11	AWAU-YKD018-H11
	24K	AWSI-HKD024-N11	AWAU-YKD024-H11

SPECIFICATION
3. Specification
3.1 Model: AWSI-HKD009-N11 / AWAU-YKD009-H11

MODEL INDOOR UNIT			AWSI-HKD009-N11		
Model Outdoor Unit			AWAU-YKD009-H11		
Installation Method of Pipe			Flared		
Characteristics	Units	Cooling	Heating		
			Average	Warm	Cold
Capacity ⁽¹⁾	kW	2.65 (1.0 -3.2)	2.7(0.82-3.3)		
Pdesign	kW	2.65	2.2	2.8	-
SEER /SCOP ⁽²⁾	W/W	6.1	4	5.1	-
Energy efficiency class		A++	A+	A+++	-
Annual energy consumption	kWh	153	770	769	-
Tbiv	°C	N/A	-7	2	-
Tol	°C	N/A	-15		
Power supply	V/Ph/Hz	220-240V/Single/50Hz			
Circuit breaker rating	A	10			
INDOOR	Fan type & quantity		Cross flow fan x1		
	Fan speeds	VL/L/M/H	RPM 800 /1000 /1150		
	Air flow ⁽³⁾	VL/L/M/H	m3/hr 270/320/420		
	External static pressure	Min-Max	Pa 0		
	Sound power level ⁽⁴⁾	VL/L/M/H	dB(A) 54		
	Sound pressure level ⁽⁵⁾	VL/L/M/H	dB(A) 23/29/34/38		
	Moisture removal		l/hr 1		
	Condensate drain tube I.D		mm 16		
	Dimensions	WxHxD	mm 715x285x194		
	Weight		kg 6.8		
	Package dimensions	WxHxD	mm 780x360x270		
	Packaged weight		kg 8.9		
	Stacking height		units 7		
	OUTDOOR	Refrigerant control		EEV	
Compressor type, model		Rotary DC Inverter			
Fan type & quantity		Axial x 1			
Fan speeds		H	RPM 810		
Air flow		H	m3/hr 1800		
Sound power level ⁽⁴⁾		H	dB(A) 61		
Sound pressure level ⁽⁵⁾		H	dB(A) 51		
Dimensions		WxHxD	mm 770x555x300		
Weight			kg 25.2		
Package dimensions		WxHxD	mm 900x585x345		
Packaged weight			kg 27.4		
Stacking height			Units 4		
Refrigerant type		R410A			
Refrigerant charge (standard connecting tubing length)		kg(5m) 0.8			
Additional charge per 1 meter		gr / 1m 15			
Connections between units		Liquid line	In.(mm) 1/4"		
	Suction line	In.(mm) 3/8"			
	Max.tubing length	m. 25			
	Max.height difference	m. 10			
Operation control type		Remote control			
Heating elements		kW NA			
Others					

(1) Rating conditions in accordance with ISO 5151 and ISO 13253 (for ducted units).

(2) SEER / SCOP calculation accordance with EN14825.

3.2 Model: AWSI-HKD012-N11 / AWAU-YKD012-H11

MODEL INDOOR UNIT		AWSI-HKD012-N11			
Model Outdoor Unit		AWAU-YKD012-H11			
Installation Method of Pipe		Flared			
Characteristics	Units	Cooling	Heating		
			Average	Warm	Cold
Capacity ⁽¹⁾	kW	3.54(1.08-4.1)	3.2(0.9-4.2)		
Pdesign	kW	3.54	2.3	2.9	-
SEER /SCOP ⁽²⁾	W/W	6.1	4.0	5.3	-
Energy efficiency class		A++	A+	A+++	-
Annual energy consumption	kWh	204	805	767	-
Tbiv	°C	N/A	-7	2	-
Tol	°C	N/A	-15		
Power supply	V/Ph/Hz	220-240V/Single/50Hz			
Circuit breaker rating	A	10			
INDOOR	Fan type & quantity		Cross flow fan x1		
	Fan speeds	VL/L/M/H	RPM 800 / 1050 / 1200		
	Air flow ⁽³⁾	VL/L/M/H	m3/hr 370/470/570		
	External static pressure	Min-Max	Pa 0		
	Sound power level ⁽⁴⁾	VL/L/M/H	dB(A) 54		
	Sound pressure level ⁽⁵⁾	VL/L/M/H	dB(A) 24/33/37/42		
	Moisture removal		l/hr 1.2		
	Condensate drain tube I.D		mm 16		
	Dimensions	WxHxD	mm 805x285x194		
	Weight		kg 7.2		
	Package dimensions	WxHxD	mm 870x360x270		
	Packaged weight		kg 9.6		
	Stacking height	units	7		
OUTDOOR	Refrigerant control		EEV		
	Compressor type, model		Rotary DC Inverter		
	Fan type & quantity		Axial x 1		
	Fan speeds	H	RPM	810	
	Air flow	H	m3/hr	1800	
	Sound power level ⁽⁴⁾	H	dB(A)	61	
	Sound pressure level ⁽⁵⁾	H	dB(A)	53	
	Dimensions	WxHxD	mm	770x555x300	
	Weight		kg	25.5	
	Package dimensions	WxHxD	mm	900x585x345	
	Packaged weight		kg	27.7	
	Stacking height		Units	4	
	Refrigerant type		R410A		
	Refrigerant charge (standard connecting tubing length)	kg(5m)	0.8		
	Additional charge per 1 meter	gr / 1m	15		
Connections between units	Liquid line	In.(mm)	1/4"		
	Suction line	In.(mm)	3/8"		
	Max.tubing length	m.	25		
	Max.height difference	m.	10		
Operation control type		Remote control			
Heating elements		kW	NA		
Others					

(1) Rating conditions in accordance with ISO 5151 and ISO 13253 (for ducted units).

(2) SEER / SCOP calculation accordance with EN14825.

3.3 Model: AWSI-HKD018-N11 / AWAU-YKD018-H11

MODEL INDOOR UNIT			AWSI-HKD018-N11		
Model Outdoor Unit			AWAU-YKD018-H11		
Installation Method of Pipe			Flared		
Characteristics	Units	Cooling	Heating		
			Average	Warm	Cold
Capacity ⁽¹⁾	kW	5.0(1.8-6.1)	5.0(1.4~6.7)		
Pdesign	kW	5	4.2	4.4	-
SEER /SCOP ⁽²⁾	W/W	6.5	4.0	5.1	-
Energy efficiency class		A++	A+	A+++	-
Annual energy consumption	kWh	270	1470	1208	-
Tbiv	°C	N/A	-7	2	-
Tol	°C	N/A	-15		
Power supply	V/Ph/Hz	220-240V/Single/50Hz			
Circuit breaker rating	A	16			
INDOOR	Fan type & quantity		Cross flow fan x1		
	Fan speeds	VL/L/M/H	RPM 700 / 800 / 1100		
	Air flow ⁽³⁾	VL/L/M/H	m3/hr 540/680/840		
	External static pressure	Min-Max	Pa 0		
	Sound power level ⁽⁴⁾	VL/L/M/H	dB(A) 57		
	Sound pressure level ⁽⁵⁾	VL/L/M/H	dB(A) 24/32/36/42		
	Moisture removal		l/hr 1.7		
	Condensate drain tube I.D		mm 16		
	Dimensions	WxHxD	mm 957x302x213		
	Weight		kg 9.5		
	Package dimensions	WxHxD	mm 1035x380x295		
	Packaged weight		kg 12.5		
	Stacking height		units 8		
OUTDOOR	Refrigerant control		EEV		
	Compressor type, model		Rotary DC Inverter		
	Fan type & quantity		Axial x 1		
	Fan speeds	H	RPM	810	
	Air flow	H	m3/hr	2100	
	Sound power level ⁽⁴⁾	H	dB(A)	65	
	Sound pressure level ⁽⁵⁾	H	dB(A)	55	
	Dimensions	WxHxD	mm	800x554x333	
	Weight		kg	37.8	
	Package dimensions	WxHxD	mm	920x615x390	
	Packaged weight		kg	40.5	
	Stacking height		Units	4	
	Refrigerant type		R410A		
	Refrigerant charge (standard connecting tubing length)		kg(5m)	1.48	
	Additional charge per 1 meter		gr / 1m	15	
Connections between units	Liquid line	In.(mm)	1/4"		
	Suction line	In.(mm)	1/2"		
	Max.tubing length	m.	30		
	Max.height difference	m.	20		
Operation control type		Remote control			
Heating elements		kW	NA		
Others					

(1) Rating conditions in accordance with ISO 5151 and ISO 13253 (for ducted units).

(2) SEER / SCOP calculation accordance with EN14825.

3.4 Model: AWSI-HKD018-N11 / AWAU-YKD018-H11

MODEL INDOOR UNIT			AWSI-HKD024-N11		
Model Outdoor Unit			AWAU-YKD024-H11		
Installation Method of Pipe			Flared		
Characteristics	Units	Cooling	Heating		
			Average	Warm	Cold
Capacity ⁽¹⁾	kW	6.8(2.7-7.8)	7.3(1.6-8.7)		
Pdesign	kW	6.8	5.5	6.3	-
SEER /SCOP ⁽²⁾	W/W	6.1	4.0	5.1	-
Energy efficiency class		A++	A+	A+++	-
Annual energy consumption	kWh	391	1925	1730	-
Tbiv	°C	N/A	-7	2	-
Tol	°C	N/A	-15		
Power supply	V/Ph/Hz	220-240V/Single/50Hz			
Circuit breaker rating	A	25			
INDOOR	Fan type & quantity		Cross flow fan x1		
	Fan speeds	VL/L/M/H	RPM 900 / 1100 / 1180		
	Air flow ⁽³⁾	VL/L/M/H	m3/hr 640/800/980		
	External static pressure	Min-Max	Pa 0		
	Sound power level ⁽⁴⁾	VL/L/M/H	dB(A) 60		
	Sound pressure level ⁽⁵⁾	VL/L/M/H	dB(A) 32/35/40/44		
	Moisture removal		l/hr 2.4		
	Condensate drain tube I.D		mm 16		
	Dimensions	WxHxD	mm 1040x327x220		
	Weight		kg 11.9		
	Package dimensions	WxHxD	mm 1120x310x405		
	Packaged weight		kg 15.2		
	Stacking height		units 8		
OUTDOOR	Refrigerant control		EEV		
	Compressor type, model		Rotary DC Inverter		
	Fan type & quantity		Axial x 1		
	Fan speeds	H	RPM	810	
	Air flow	H	m3/hr	2700	
	Sound power level ⁽⁴⁾	H	dB(A)	66	
	Sound pressure level ⁽⁵⁾	H	dB(A)	59	
	Dimensions	WxHxD	mm	845x702x363	
	Weight		kg	48.4	
	Package dimensions	WxHxD	mm	965x755x395	
	Packaged weight		kg	51.6	
	Stacking height		Units	3	
	Refrigerant type			R410A	
	Refrigerant charge (standard connecting tubing length)	kg(5m)		1.85	
	Additional charge per 1 meter	gr / 1m		15	
Connections between units	Liquid line	In.(mm)	3/8"		
	Suction line	In.(mm)	5/8"		
	Max.tubing length	m.	50		
	Max.height difference	m.	25		
Operation control type		Remote control			
Heating elements	kW	NA			
Others					

(1) Rating conditions in accordance with ISO 5151 and ISO 13253 (for ducted units).

(2) SEER / SCOP calculation accordance with EN14825.

4. Dimension

4.1 Indoor Unit

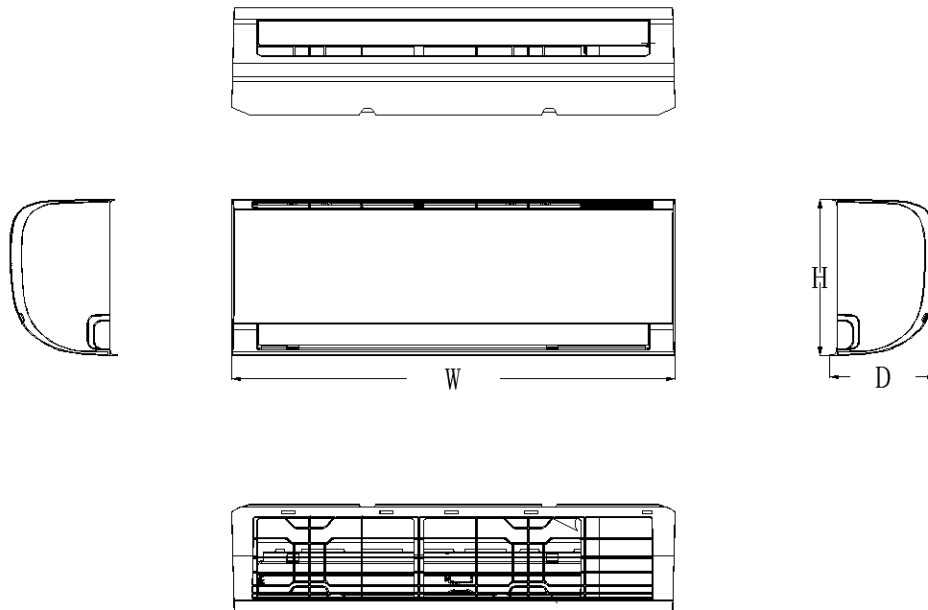

Model	W	D	H
AWSI-HKD009-N11	715	194	285
AWSI-HKD012-N11	805	194	285
AWSI-HKD018-N11	957	213	302
AWSI-HKD024-N11	1040	220	327

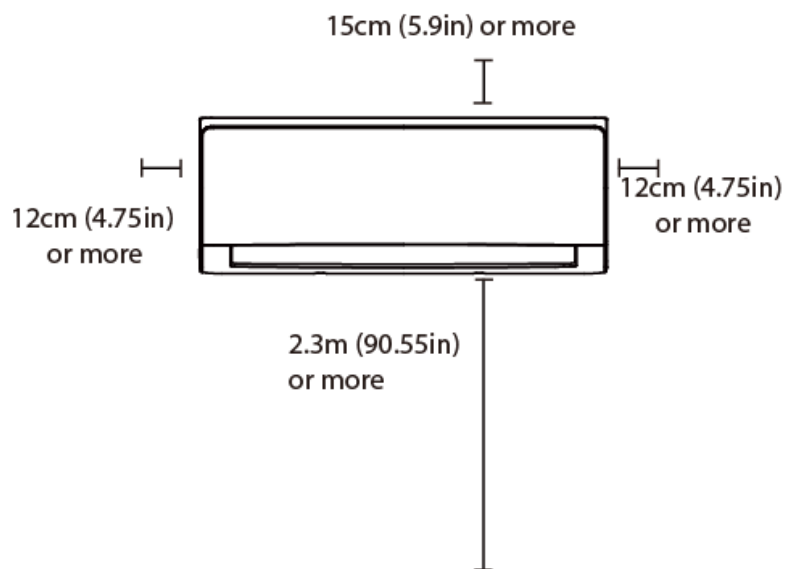

For AWSI-HKD009-N11,

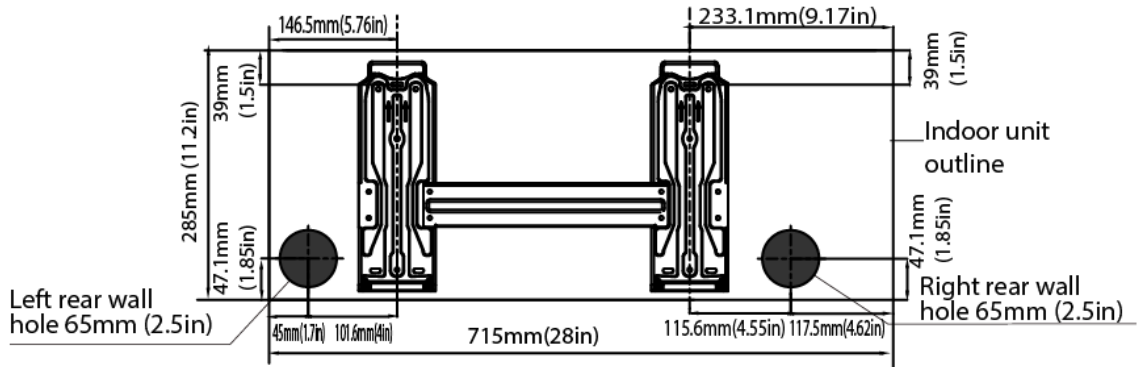

Model A

For AWSI-HKD012-N11,

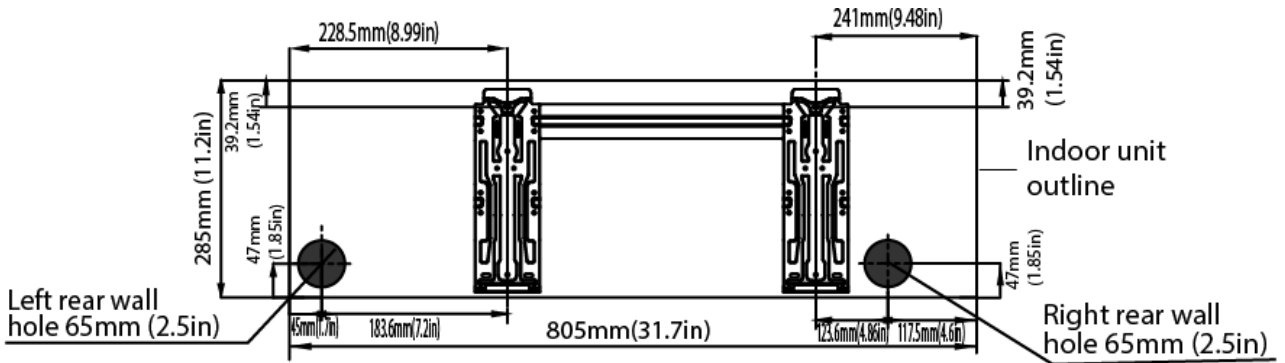

Model B

For AWSI-HKD018-N11,

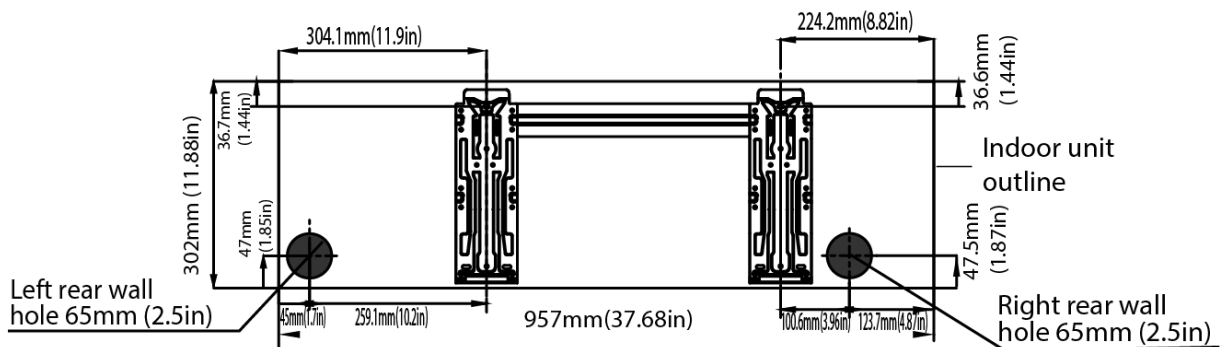

Model C

For AWSI-HKD024-N11,

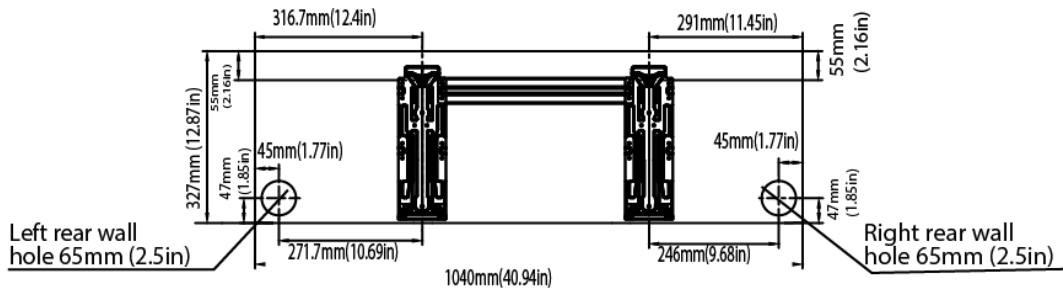

Model D

4.2 Outdoor Unit

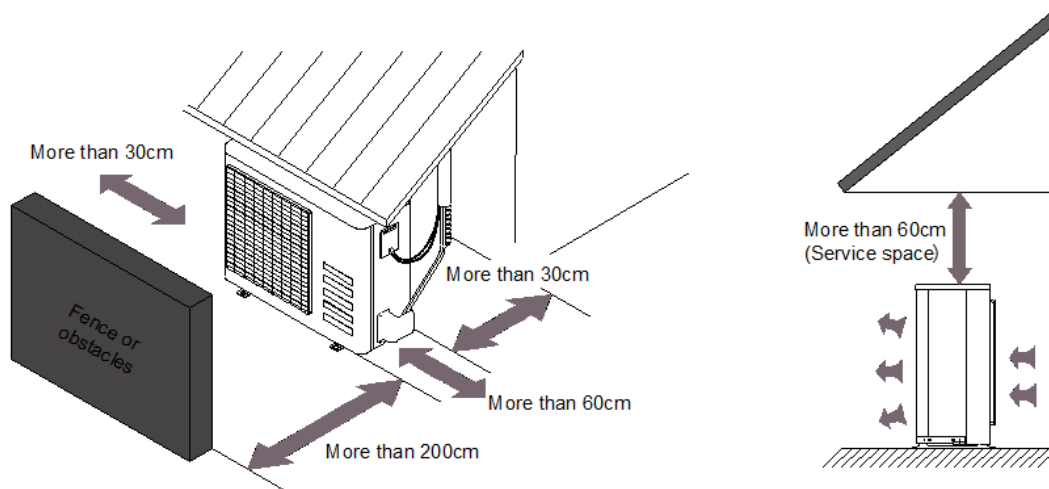

For AWAU-YKD009-H11 ,AWAU-YKD012-H11,

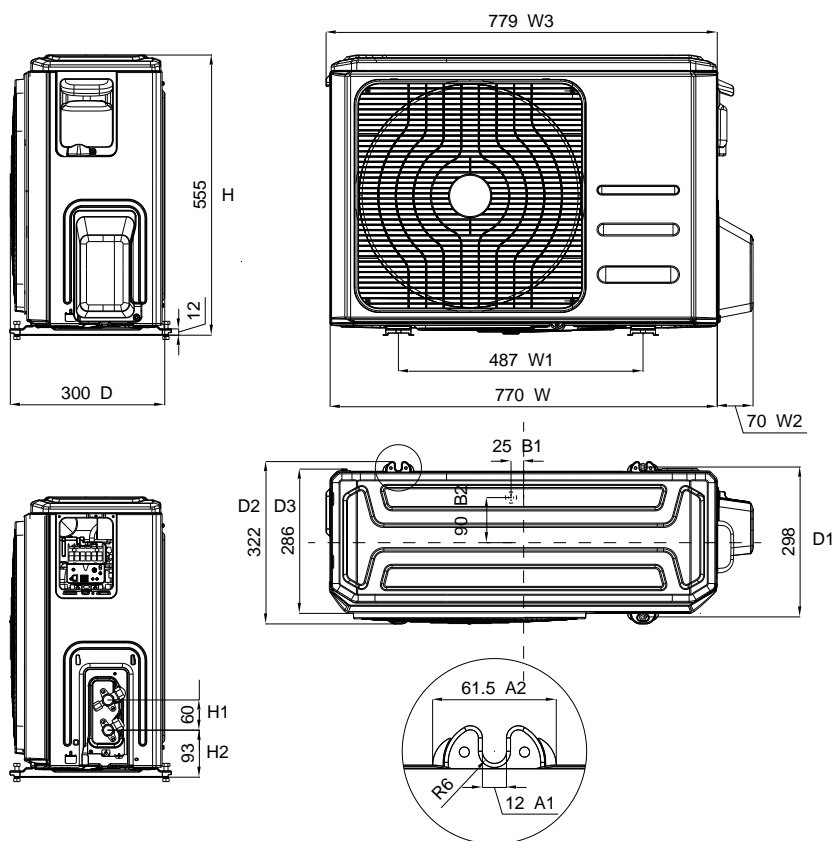

DIMENSION

For AWAU-YKD018-H11,

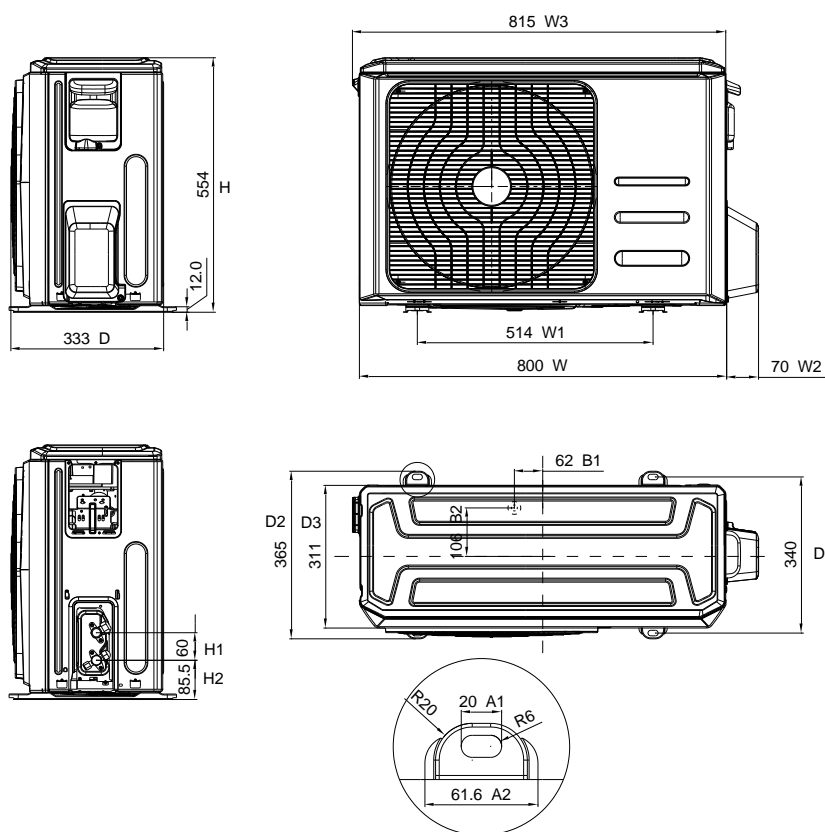

For AWAU-YKD024-H11,

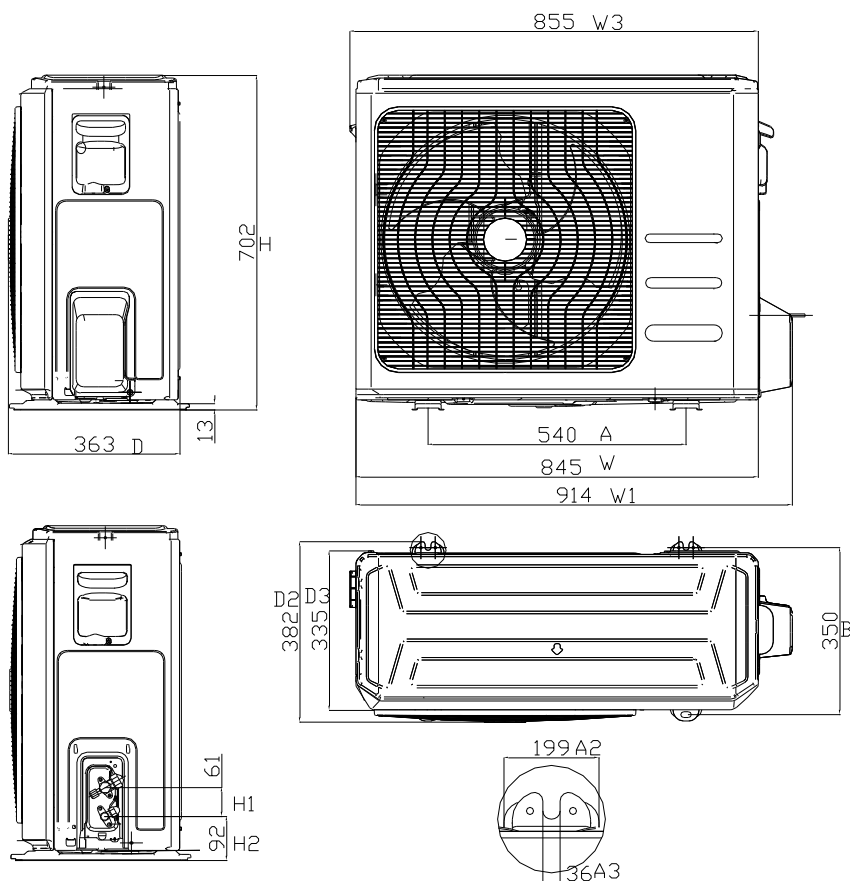

5. Refrigerant Cycle Diagram

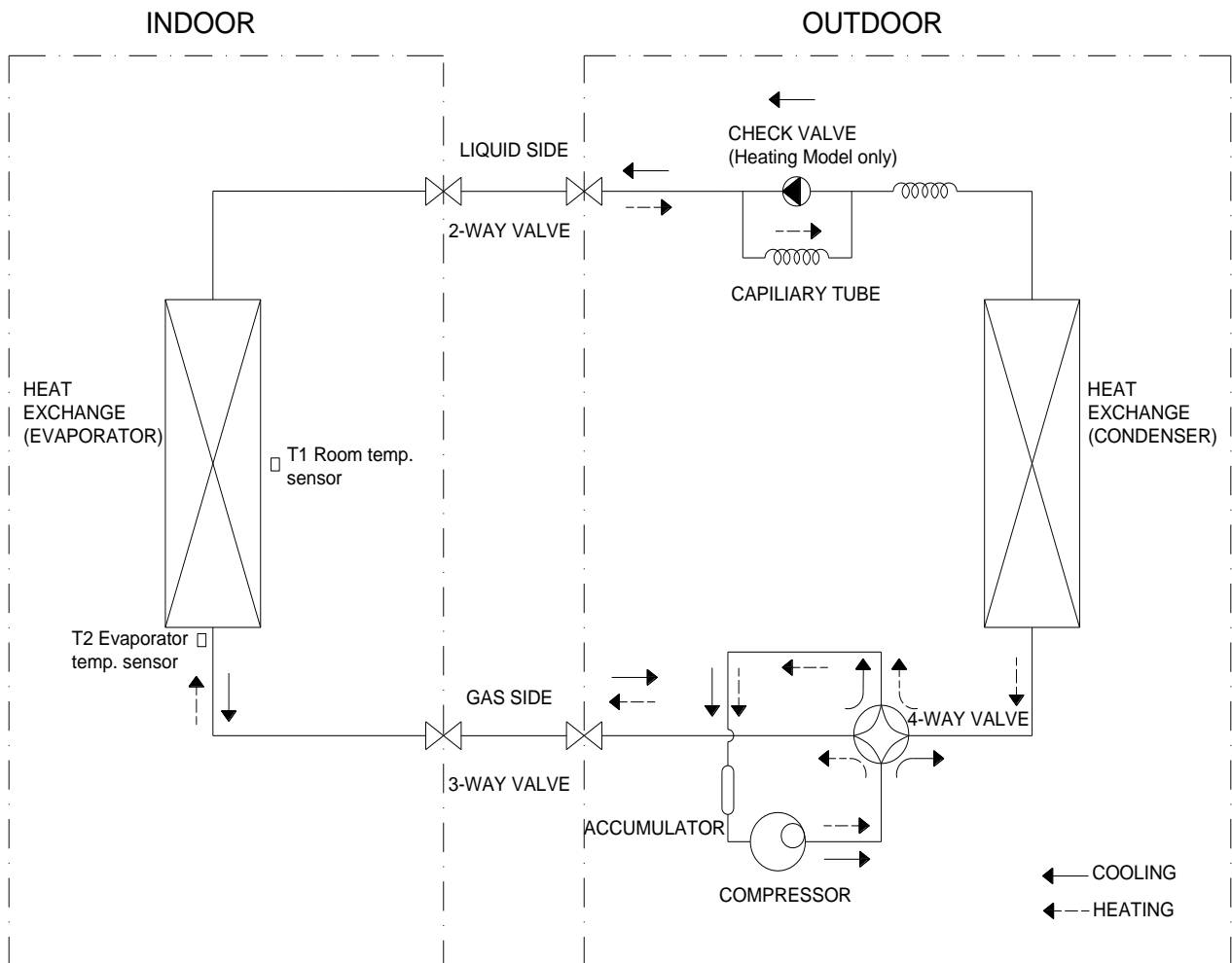

6. Wiring Diagram

6.1 Model: AWSI-HKD009-N11, AWSI-HKD012-N11, AWSI-HKD018-N11, AWSI-HKD024-N11

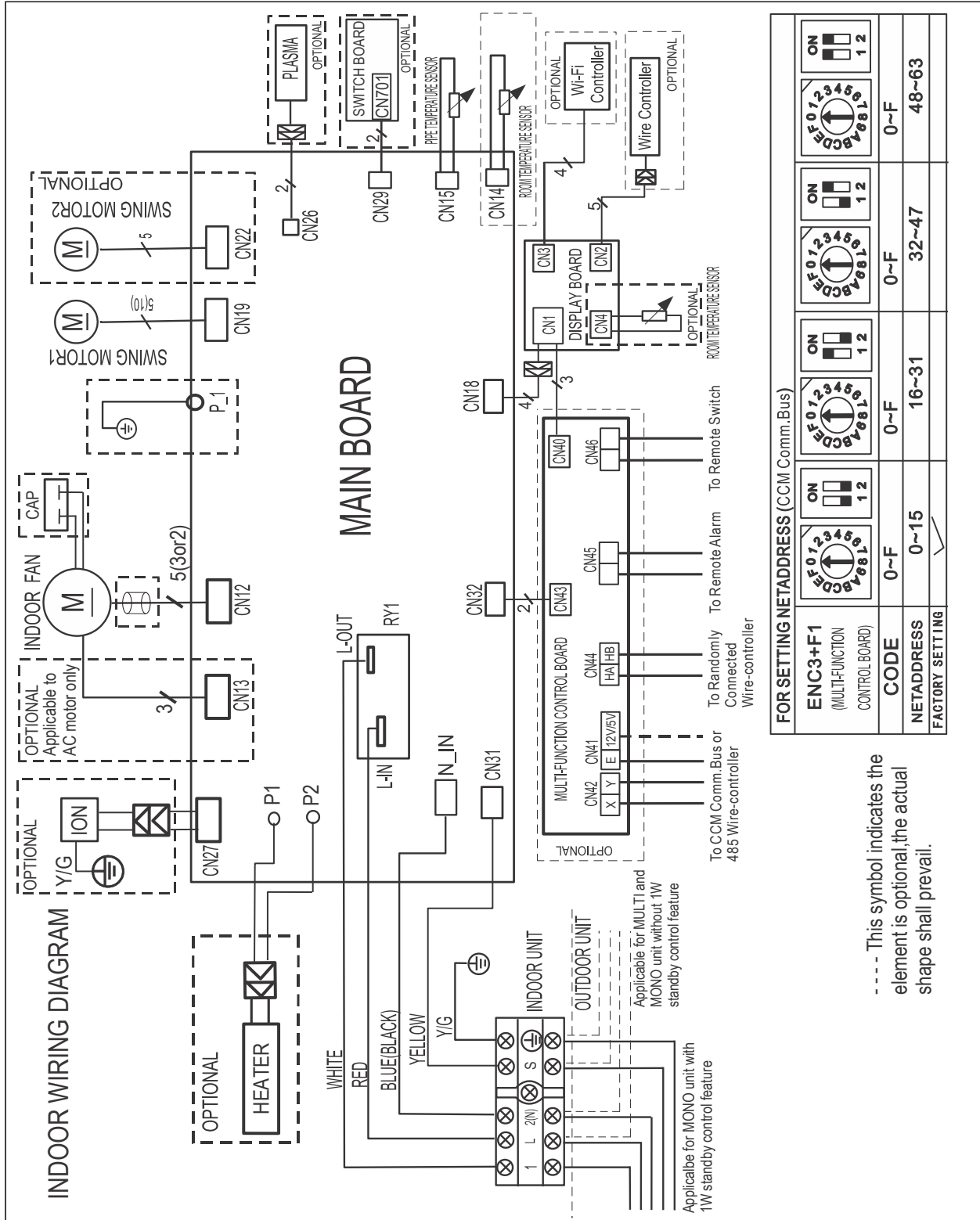

6.2 Model: AWAU-YKD009-H11, AWAU-YKD012-H11

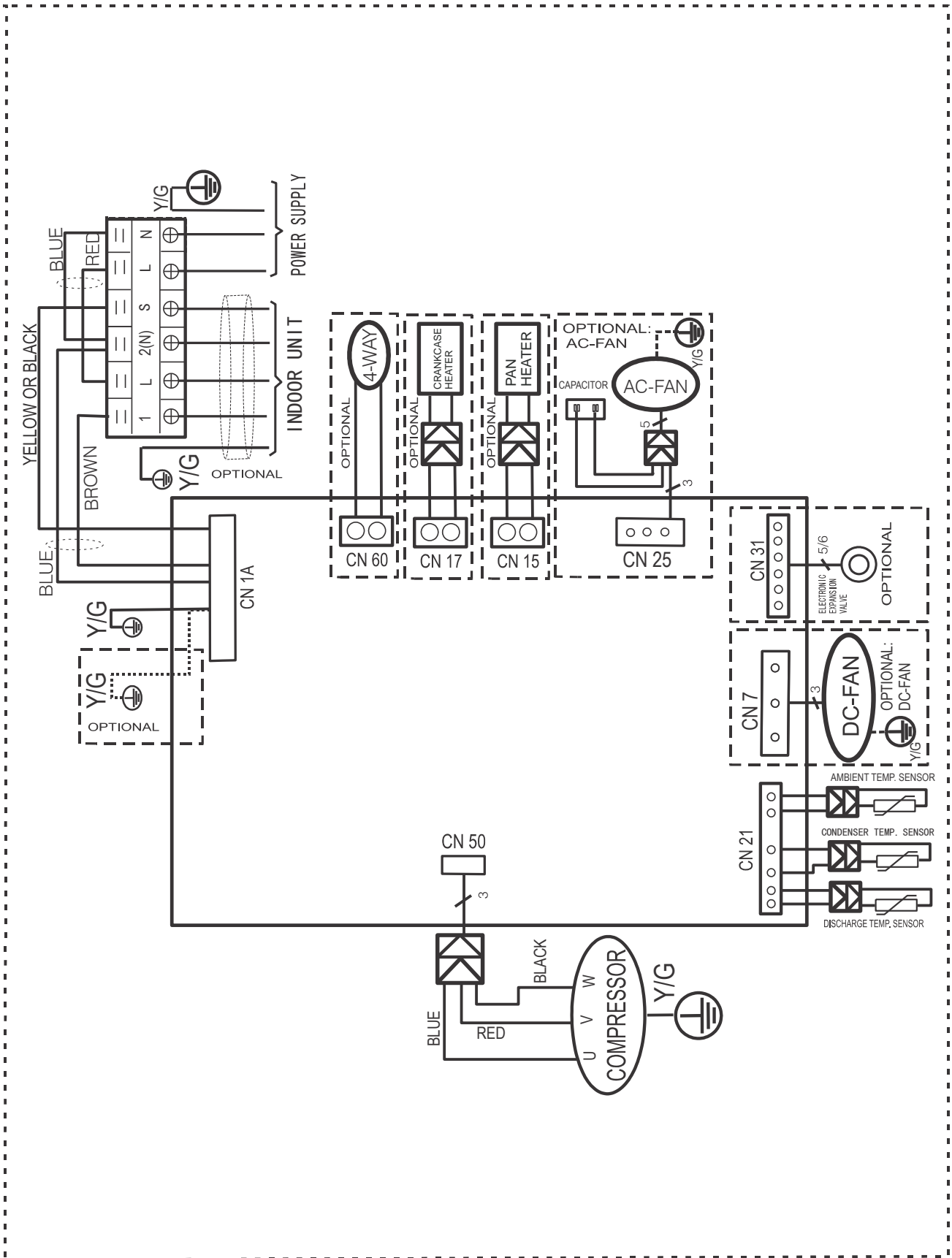

6.3 Model: AWAU-YKD018-H11

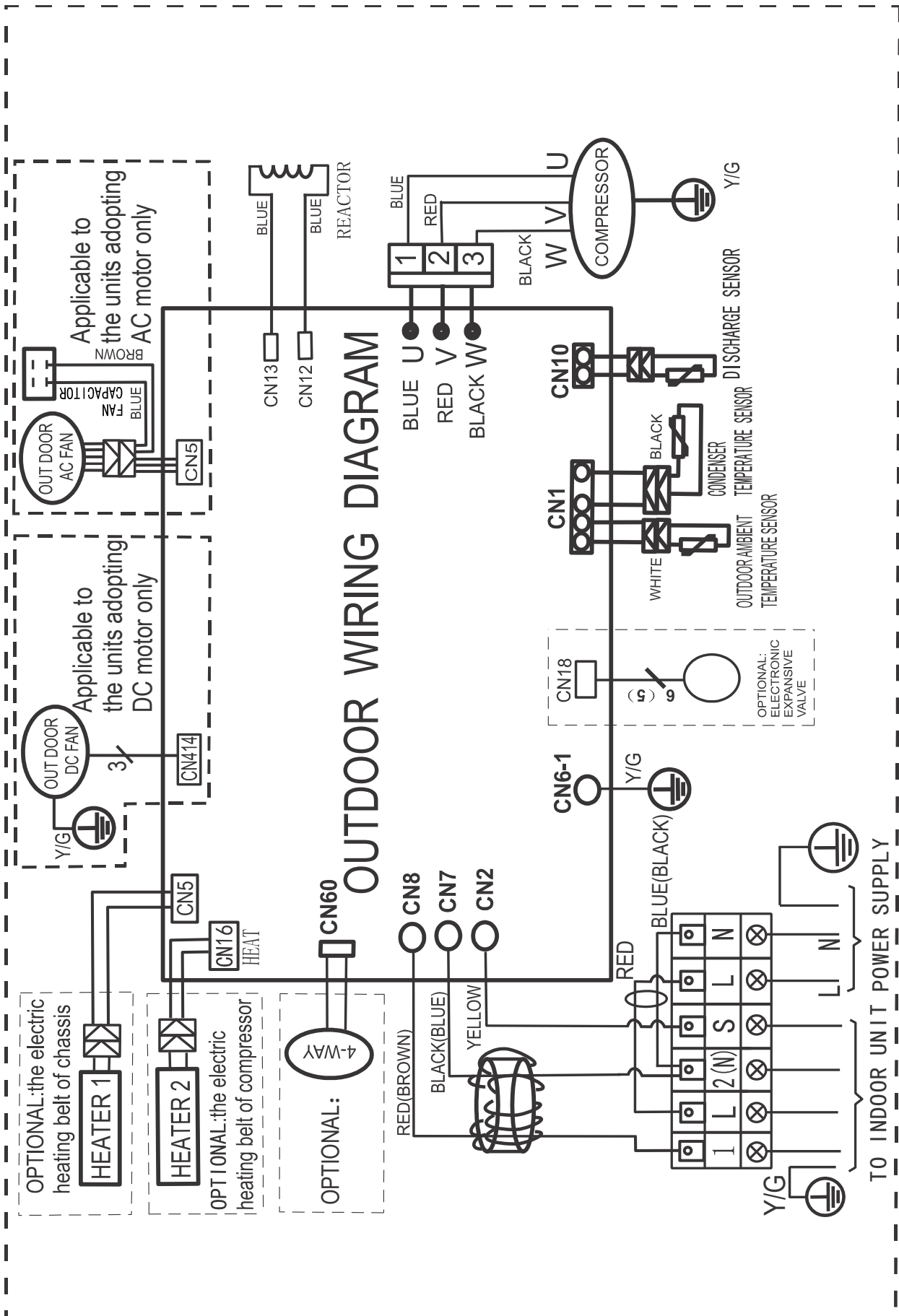

6.4 Model: AWAU-YKD024-H11

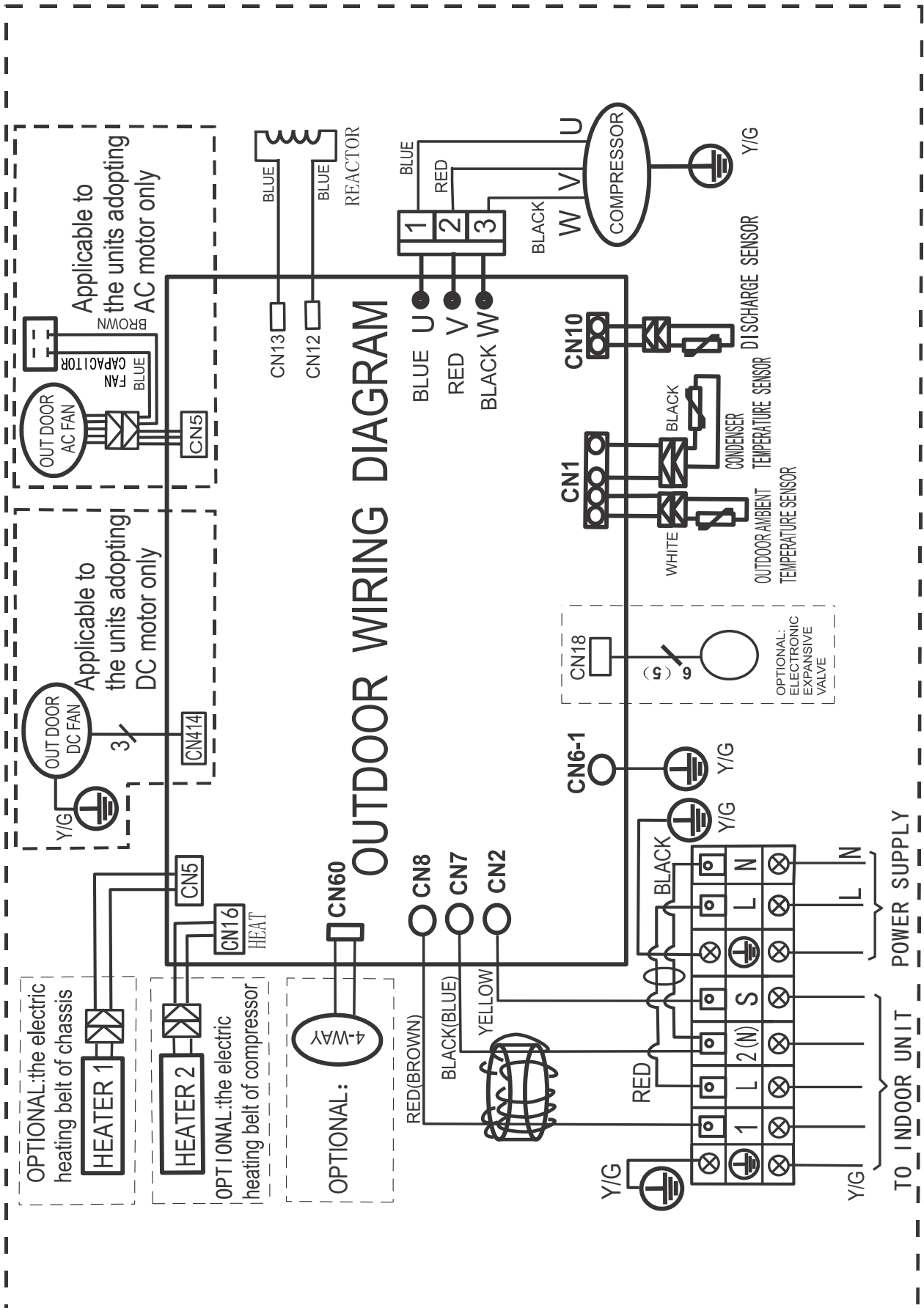

7. Installation Details

7.1 Wrench torque sheet for installation

Outside diameter		Torque	Additional tightening torque
mm	inch	N.cm	N.cm
Φ6.35	1/4	1500(153kgf.cm)	1600(163kgf.cm)
Φ9.52	3/8	2500(255kgf.cm)	2600(265kgf.cm)
Φ12.7	1/2	3500(357kgf.cm)	3600(367kgf.cm)
Φ15.9	5/8	4500(459kgf.cm)	4700(479kgf.cm)
Φ19	3/4	6500(663kgf.cm)	6700(683kgf.cm)

7.2 Connecting the cables

The power cord of connect should be selected according to the following specifications sheet.

Rated current of appliance	Nominal cross-sectional area (mm ²)
>3 and ≤6	0.75
>6 and ≤10	1
>10 and ≤16	1.5
>16 and ≤25	2.5

The cable size and the current of the fuse or switch are determined by the maximum current indicated on the nameplate which located on the side panel of the unit. Please refer to the nameplate before selecting the cable, fuse and switch.

7.3 Pipe length and the elevation

The pipe length and refrigerant amount:

Model	Pipe size		Standard length (m)	Max. Elevation B (m)	Max. Length A (m)	Additional refrigerant (g/m)
	Gas	Liquid				
AWSI-HKD009-N11+AWAU-YKD009-H11	3/8" (Φ9.52)	1/4" (Φ6.35)	5	10	25	15
AWSI-HKD012-N11+AWAU-YKD012-H11	3/8" (Φ9.52)	1/4" (Φ6.35)	5	10	25	15
AWSI-HKD018-N11+AWAU-YKD018-H11	1/2" (Φ12.7)	1/4" (Φ6.35)	5	20	30	15
AWSI-HKD024-N11+AWAU-YKD024-H11	5/8" (Φ15.9)	3/8" (Φ9.52)	5	25	50	30

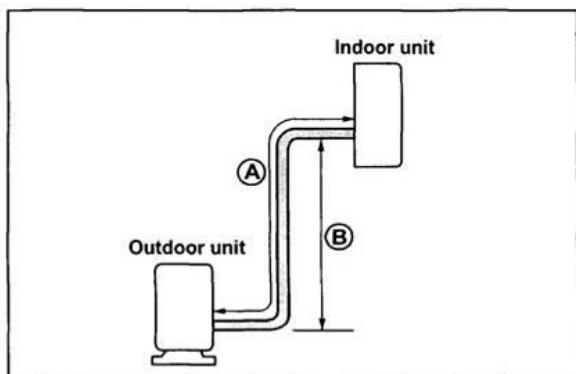

Caution:

The capacity test is based on the standard length and the maximum permissible length is based on the system reliability.

INSTALLATION DETAILS

7.4 Installation for the first time

Air and moisture in the refrigerant system have undesirable effects as below:

- Pressure in the system rises.
- Operating current rises.
- Cooling or heating efficiency drops.
- Moisture in the refrigerant circuit may freeze and block capillary tubing.
- Water may lead to corrosion of parts in the refrigerant system.

Therefore, the indoor units and the pipes between indoor and outdoor units must be leak tested and evacuated to remove gas and moisture from the system.

Gas leak check (Soap water method):

Apply soap water or a liquid neutral detergent on the indoor unit connections or outdoor unit connections by a soft brush to check for leakage of the connecting points of the piping. If bubbles come out, the pipes have leakage.

1. Air purging with vacuum pump

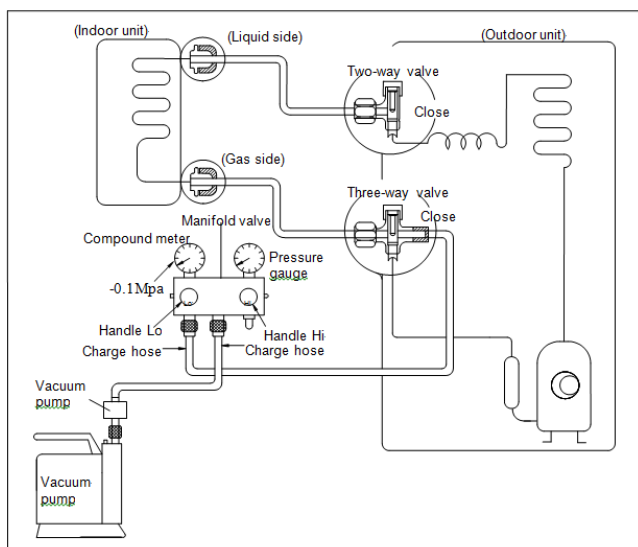

- 1) Completely tighten the flare nuts of the indoor and outdoor units, confirm that both the 2-way and 3-way valves are set to the closed position.
- 2) Connect the charge hose with the push pin of handle lo to the 3-way valves gas service port..
- 3) Connect the charge hose of handle hi connection to the vacuum pump.
- 4) Fully open the handle Lo of the manifold valve.
- 5) Operate the vacuum pump to evacuate.
- 6) Make evacuation for 30 minutes and check

whether the compound meter indicates - 0.1Mpa. If the meter does not indicate - 0.1Mpa after pumping 30 minutes, it should be pumped 20 minutes more. If the pressure can't achieve -0.1Mpa after pumping 50 minutes, please check if there are some leakage points.

Fully close the handle Lo valve of the manifold valve and stop the operation of the vacuum pump. Confirm that the gauge needle does not move (approximately 5 minutes after turning off the vacuum pump).

- 7) Turn the flare nut of the 3-way valves about 45° counterclockwise for 6 or 7seconds after the gas

coming out, then tighten the flare nut again. Make sure the pressure display in the pressure indicator is a little higher than the atmosphere pressure. Then remove the charge hose from the 3 way valve.

- 8) Fully open the 2 way valve and 3 way valve and securely tighten the cap of the 3 way valve.

2. Adding the refrigerant if the pipe length >5m

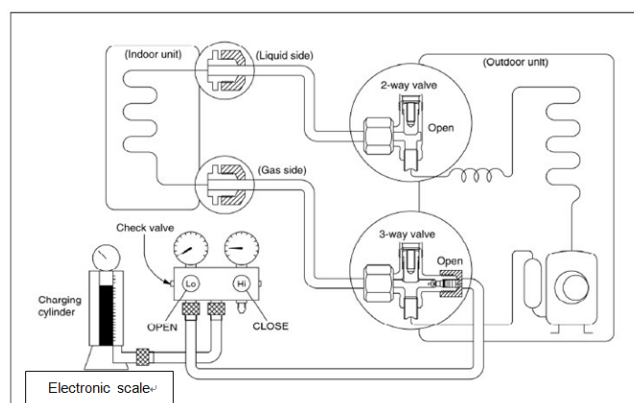

Procedure:

- 1). Connect the charge hose to the charging cylinder, open the 2-way valve and the 3-way valve.

Connect the charge hose which you disconnected from the vacuum pump to the valve at the bottom of the cylinder. If the refrigerant is R410A, make the cylinder bottom up to ensure the liquid charge.

- 2). Purge the air from the charge hose.

Open the valve at the bottom of the cylinder and press the check valve on the charge set to purge the air (be careful of the liquid refrigerant).

- 3) Put the charging cylinder onto the electronic

scale and record the weight.

4) Operate the air conditioner at the cooling mode.

5) Open the valves (Low side) on the charge set and charge the system with liquid refrigerant.

6).When the electronic scale displays the proper weight (refer to the table), disconnect the charge hose from the 3-way valve's service port immediately and turn off the air conditioner before disconnecting the hose.

7). Mount the valve stem caps and the service port Use torque wrench to tighten the service port cap to a torque of 18N.m.

Be sure to check for gas leakage.

7.5 Adding the refrigerant after running the system for many years

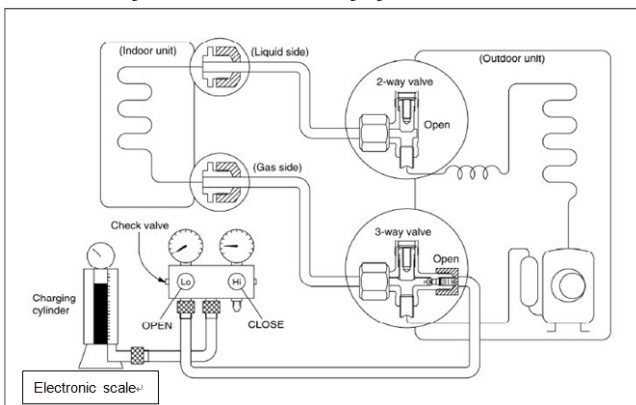

Procedure:

- 1). Connect the charge hose to the 3-way service port, open the 2-way valve and the 3-way valve. Connect the charge hose to the valve at the bottom of the cylinder. If the refrigerant is R410A, make the cylinder bottom up to ensure liquid charge.
- 2). Purge the air from the charge hose. Open the valve at the bottom of the cylinder and press the check valve on the charge set to purge the air (be careful of the liquid refrigerant).
- 3) Put the charging cylinder onto the electronic scale and record the weight.
- 4) Operate the air conditioner at the cooling mode.
- 5) Open the valves (Low side) on the charge set and charge the system with liquid refrigerant.
- 6).When the electronic scale displays the proper weight (refer to the gauge and the pressure of the low side), disconnect the charge hose from the 3-way valve's service port immediately and turn off

the air conditioner before disconnecting the hose.

7). Mount the valve stem caps and the service port Use torque wrench to tighten the service port cap to a torque of 18N.m.

Be sure to check for gas leakage.

7.6 Re-installation while the indoor unit need to be repaired

1. Collecting the refrigerant into the outdoor unit

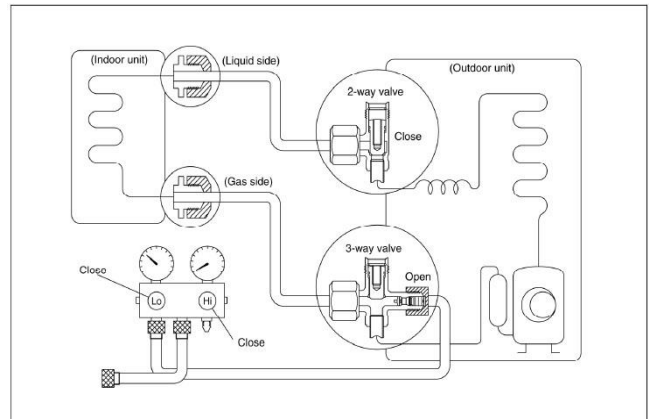

Procedure

- 1). Confirm that both the 2-way and 3-way valves are set to the opened position. Remove the valve stem caps and confirm that the valve stems are in the opened position. Be sure to use a hexagonal wrench to operate the valve stems.
- 2). Connect the charge hose with the push pin of handle lo to the 3-way valves gas service port.
- 3). Air purging of the charge hose. Open the handle Lo valve of the manifold valve slightly to purge air from the charge hose for 5 seconds and then close it quickly.
- 4). Set the 2-way valve to the close position.
- 5). Operate the air conditioner at the cooling cycle and stop it when the gauge indicates 0.1MPa.
- 6). Set the 3-way valve to the closed position immediately. Do this quickly so that the gauge ends up indicating 0.3 to 0.5Mpa. Disconnect the charge set, and tighten the 2-way and 3-way valve's stem nuts. Use a torque wrench to tighten the 3-way valves service port cap to a torque of 18N.m. Be sure to check for gas leakage.

INSTALLATION DETAILS

2. Air purging with vacuum pump

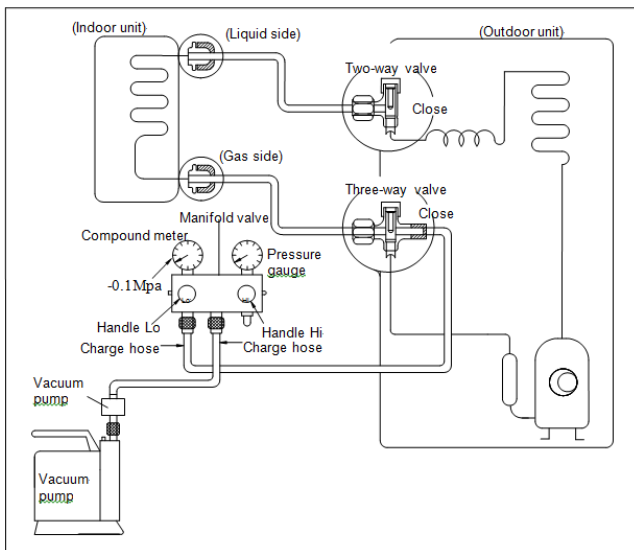

- 1) Completely tighten the flare nuts of the indoor and outdoor units, confirm that both the 2-way and 3-way valves are set to the closed position.
- 2) Connect the charge hose with the push pin of handle lo to the 3-way valves gas service port.
- 3) Connect the charge hose of handle hi connection to the vacuum pump.
- 4) Fully open the handle Lo of the manifold valve.
- 5) Operate the vacuum pump to evacuate.
- 6) Make evacuation for 30 minutes and check whether the compound meter indicates -0.1Mpa. If the meter does not indicate -0.1Mpa after pumping 30 minutes, it should be pumped 20 minutes more. If the pressure can't achieve -0.1Mpa after pumping 50 minutes, please check if there are some leakage points. Fully close the handle Lo valve of the manifold valve and stop the operation of the vacuum pump. Confirm that the gauge needle does not move (approximately 5 minutes after turning off the vacuum pump).
- 7) Turn the flare nut of the 3-way valves about 45° counterclockwise for 6 or 7 seconds after the gas coming out, then tighten the flare nut again. Make sure the pressure display in the pressure indicator is a little higher than the atmosphere pressure. Then remove the charge hose from the 3 way valve.
- 8) Fully open the 2 way valve and 3 way valve and securely tighten the cap of the 3 way valve.

7.7 Re-installation while the outdoor unit need to be repaired

1. Evacuation for the whole system

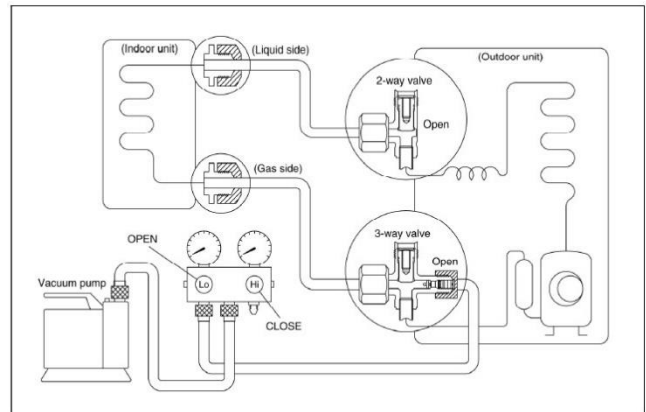

Procedure:

- 1). Confirm that both the 2-way and 3-way valves are set to the opened position.
- 2). Connect the vacuum pump to 3-way valve's service port.
- 3). Evacuation for approximately one hour. Confirm that the compound meter indicates -0.1Mpa.
- 4). Close the valve (Low side) on the charge set, turn off the vacuum pump, and confirm that the gauge needle does not move (approximately 5 minutes after turning off the vacuum pump).
- 5). Disconnect the charge hose from the vacuum pump.

2. Refrigerant charging

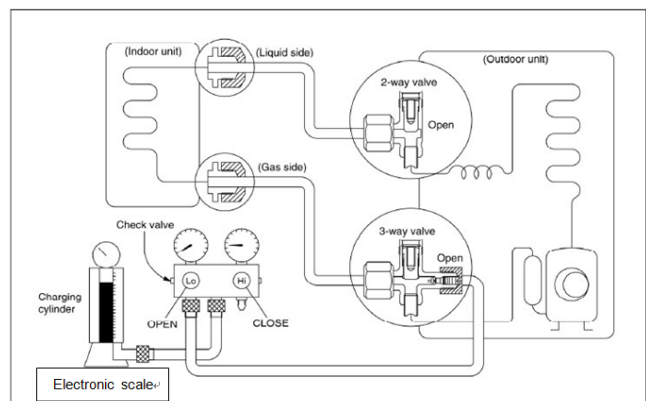

Procedure:

- 1). Connect the charge hose to the charging cylinder, open the 2-way valve and the 3-way valve
Connect the charge hose which you disconnected

from the vacuum pump to the valve at the bottom of the cylinder. If the refrigerant is R410A, make the cylinder bottom up to ensure liquid charge.

2). Purge the air from the charge hose

Open the valve at the bottom of the cylinder and press the check valve on the charge set to purge the air (be careful of the liquid refrigerant).

3) Put the charging cylinder onto the electronic scale and record the weight.

4). Open the valves (Low side) on the charge set and charge the system with liquid refrigerant

If the system cannot be charge with the specified amount of refrigerant, or can be charged with a little at a time (approximately 150g each time) , operating the air conditioner in the cooling cycle; however, one time is not sufficient, wait approximately 1 minute and then repeat the procedure.

5).When the electronic scale displays the proper weight, disconnect the charge hose from the 3-way valve's service port immediately

If the system has been charged with liquid refrigerant while operating the air conditioner, turn off the air conditioner before disconnecting the hose.

6). Mounted the valve stem caps and the service port

Use torque wrench to tighten the service port cap to a torque of 18N.m.

Be sure to check for gas leakage.

8. Operation Characteristics

Mode \ Temperature	Cooling operation	Heating operation	Drying operation
Room temperature	17°C~32°C (62°F~90°F)	0°C~30°C (32°F~86°F)	10°C~32°C (50°F~90°F)
Outdoor temperature	-15°C~50°C (5°F~122°F)	-15°C~30°C (5°F~86°F)	0°C~50°C (32°F~122°F)

CAUTION:

1. If the air conditioner is used beyond the above conditions, certain safety protection features may come into operation and cause the unit to operate abnormally.

2. The room relative humidity should be less than 80%. If the air conditioner operates beyond this figure, the surface of the air conditioner may attract condensation. Please set the vertical air flow louver to its maximum angle (vertically to the floor), and set HIGH fan mode.

3. For units with auxiliary electric heater .When outside temperature is below 0°C(32°F),we strongly recommend keeping the unit plugged in at all times to ensure smooth ongoing performance.

4. The optimum performance will be achieved during this operating temperature zone.

9. Electronic function

9.1 Abbreviation

- T1: Indoor room temperature
- T2: Coil temperature of evaporator
- T3: Coil temperature of condenser
- T4: Outdoor ambient temperature
- T5: Compressor discharge temperature

9.2 Display function

7.2.1 Icon explanation on indoor display board.



“fresh” when fresh feature is activated(if applicable).

“defrost” when defrosting is activated.

“run” when the unit is on.

“timer” when TIMER is set.

Digital display(for some units):

Displays the temperature settings when the air conditioner is operational.

Displays the room temperature in Fan and Drying mode.

Displays the self-diagnostic codes.

Displays ‘**ON**’ for three seconds when Timer ON, Fresh, Swing, Turbo or Silence feature is activated.

Displays ‘**OF**’ for three seconds when Timer OFF, Fresh, Swing, Turbo or Silence feature is

cancelled.

Displays ‘**DF**’ under defrosting operation.

Displays ‘**CF**’ when anti-cold air feature is activated under heating mode.

Displays ‘**SC**’ during self clean operation (if applicable).

Displays ‘**FP**’ when freeze protection is turned on (if applicable).

NOTE:

A guide on using the infrared remote is not included in this literature package.

ELECTRONIC FUNCTION

9.3 Main Protection

9.3.1 Three minutes delay at restart for compressor

Less than 1 minute delay for the 1st time start-up and 3 minutes delay for others.

9.3.2 Temperature protection of compressor top

The unit will stop working when the compressor top temp. protector cut off, and will restart after the compressor top temp. protector restart.

9.3.3 Temperature protection of compressor discharge

Compressor discharge temp. $T_5 > 115^{\circ}\text{C}$ for 5s, compressor stops.

9.3.4 Fan speed is out of control

When indoor fan speed keeps too low (300RPM) for certain time, the unit will stop and the LED will display the failure.

9.3.5 Inverter module protection

The Inverter module has a protection function about current, voltage and temperature. If these protections happen, the corresponding code will display on indoor unit and the unit will stop working.

9.3.6 Indoor fan delayed open function

When the unit starts up, the louver will be active immediately and the indoor fan will open 7s later.

If the unit runs in heating mode, the indoor fan will be also controlled by anti-cold wind function.

9.3.7 Compressor preheating functions

Preheating permitting condition:

When T_4 (outdoor ambient temperature) $< 3^{\circ}\text{C}$, the preheating function will be activated.

9.3.8 Sensor protection at open circuit and breaking disconnection.

When there's only one temperature sensor in malfunction, the air conditioner will keep working but show the error code, in case of any emergency use.

When there's more than one temperature sensor in malfunction, the air conditioner will stop working.

9.3.9 Refrigerant leakage detection

This function is only active in cooling mode. It can better prevent the compressor being damaged by refrigerant leakage or compressor overload.

Open condition:

When compressor is active, the value of the Coil temperature of evaporator T_2 has no change or very little change.

9.4 Operation Modes and Functions

9.4.1 Fan mode

- (1) Outdoor fan and compressor stop.
- (2) Temperature setting function is disabled, and no setting temperature is displayed.
- (3) Indoor fan can be set to high/med/low/auto.
- (4) The louver operates same as in cooling mode.
- (5) Auto fan:

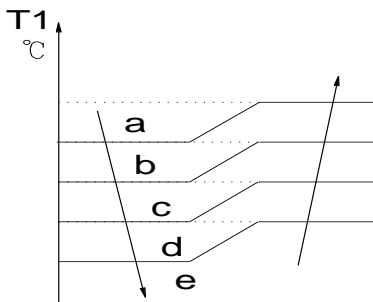

9.4.2 Cooling Mode

9.4.2.1 Compressor running rules

When $T1 - Ts < \Delta T - 2^{\circ}\text{C}$, the compressor will stop,
 when $T1 - Ts > \Delta T - 0.5^{\circ}\text{C}$, the compressor will be activated.

ΔT is the programmed parameter of temperature compensation.

When the AC run in mute mode, the compressor will run with low frequency.

When the current is more than setting value, the current protection function will be activated, and the compressor will stop.

9.4.2.2 Outdoor fan running rules

The outdoor unit will be run at different fan speed according to T4.

For different outdoor units, the fan speeds are different.

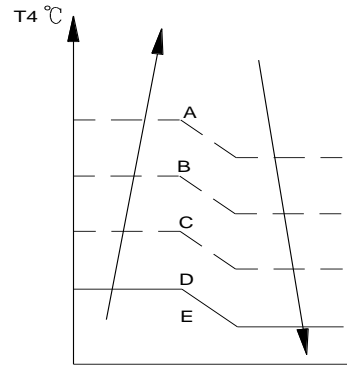

9.4.2.3 Indoor fan running rules

In cooling mode, indoor fan runs all the time and the speed can be selected as high, medium, low and auto.

When the setting temp. is reached, if the compressor stop running, indoor fan motor will run in Minimum speed or setting speed.

The indoor fan is controlled as below:

Setting fan speed	T1-Td °C(°F)	Actual fan speed
H	A	H+ (H+=H+G)
	B	H (=H)
	C	H- (H-=H-G)
M	D	M+ (M+=M+Z)
	E	M (M=M)
	F	M- (M-=M-Z)
L	G	L+ (L+=L+D)
	H	L (L=L)
	I	L- (L-=L-D)

The auto fan acts as below rules:

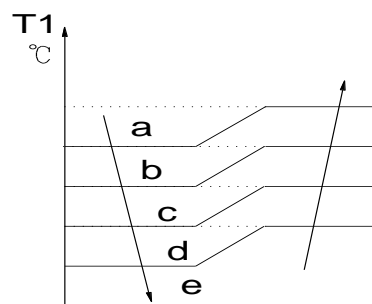

9.4.2.4 Condenser temperature protection

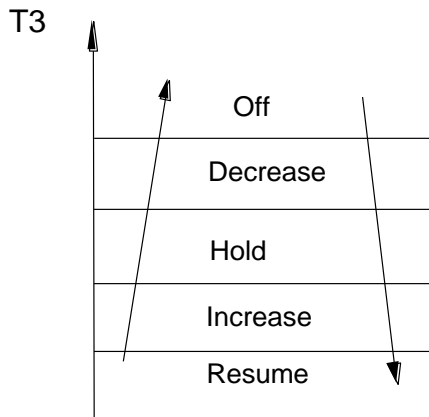

When condenser temperature temp. is more than setting value, the compressor will stop.

9.4.2.5 Evaporator temperature protection

When Evaporator temperature temp. is less than setting value, the compressor will stop.

9.4.3 Heating Mode

9.4.3.1 Compressor running rules

When $T1 - T_s > -\Delta T$, the compressor will stop, when $T1 - T_s < \Delta T - 1.5$, the compressor will be on.

ΔT is the programmed parameter of temperature compensation.

When the AC run in mute mode, the compressor will run with low frequency.

When the current is more than setting value, the current protection function will be activated and the compressor will stop.

9.4.3.2 Outdoor fan running rules

The outdoor unit will be run at different fan speed according to $T4$.

For different outdoor units, the fan speeds are different.

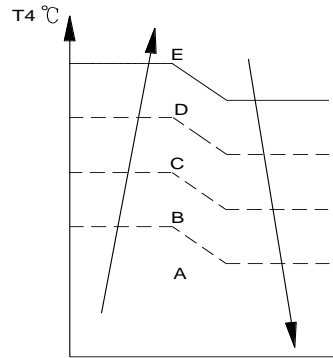

9.4.3.3 Indoor fan running rules

When the compressor is on, the indoor fan can be set to high/med/low/auto/mute.

When indoor unit coil temp. is low, the anti-cold air function will start and indoor fan motor will run at low speed, the speed can't be changed, when the temp. is lower than setting value, the indoor fan motor will stop.

When the indoor temp reaches the setting temp., the compressor will stop, the indoor fan motor will run at the minimum speed or setting speed. (The anti-cold air function is valid).

The indoor fan is controlled as below:

Setting fan speed	$T1 - T_d$ °C	Actual fan speed
H		H- (H=H-G)
		H (=H)
		H+(H+=H+G)
M		M-(M=M-Z)
		M(M=M)
		M+(M+=M+Z)
L		L-(L=L-D)
		L(L=L)
		L+(L+=L+D)

Auto fan action in heating mode:

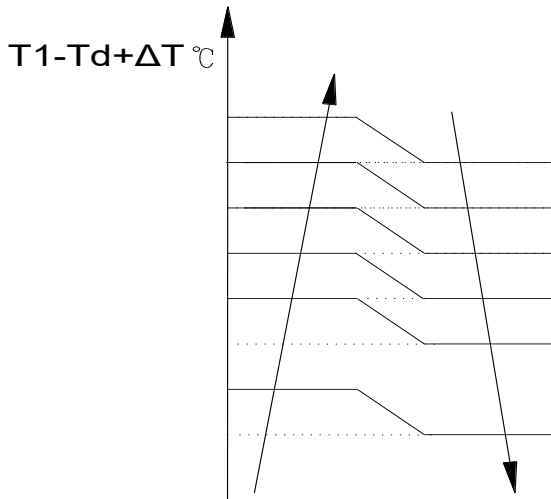

9.4.3.4 Defrosting mode

AC will enter the defrosting mode according to the value of temp. of T3 and the value range of temp. change of T3 and also the compressor running time.

During the defrosting mode, the compressor keep running, indoor and outdoor motor will stop, defrost lamp of the indoor unit will be lighted.

If any one of the following items is satisfied, the defrosting will finish and the machine will turn to normal heating mode.

- T3 rises to be higher than TCDE1°C.
- T3 keeps to be higher than TCDE2°C for 80 seconds.
- The machine has run for 15 minutes in defrosting mode.

9.4.3.5 Evaporator coil temperature protection

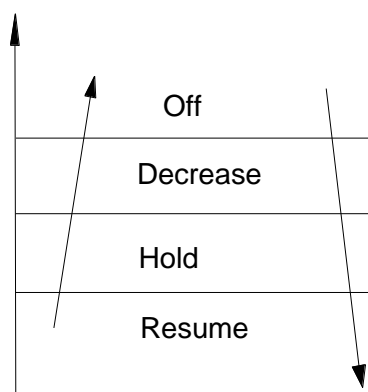

When evaporator temperature temp. is more than the setting protection value, the

compressor will stop.

9.4.4 Auto-mode

This mode can be chosen with remote controller and the setting temperature can be changed between 17°C~30°C

In auto mode, the machine will choose cooling, heating or fan-only mode according to ΔT ($\Delta T = T1 - Ts$).

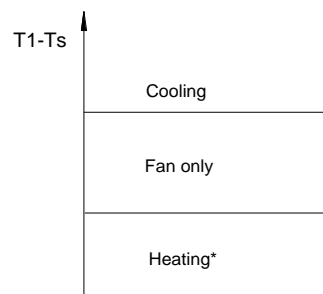

Heating*: For cooling only models, they will run at fan speed

Indoor fan will run at auto fan of the relevant mode.

The louver operates same as in relevant mode. If the machine switches mode between heating and cooling, the compressor will keep stopping for certain time and then choose mode according to T1-Ts.

If the setting temperature is modified, the machine will choose running function again.

9.4.5 Drying mode

Indoor fan speed is fixed at breeze and can't be changed. The louver angle is the same as in cooling mode.

All protections are active and the same as that in cooling mode.

9.4.6 Forced operation function

Forced cooling mode:

The compressor and outdoor fan keep running and the indoor fan runs at low speed. After running for 30 minutes, AC will turn to auto mode with 24°C setting temperature.

Forced auto mode:

ELECTRONIC FUNCTION

The action of forced auto mode is the same as normal auto mode with 24°C setting temperature. When AC receives signals, such as switch on, switch off, timer on, timer off, mode setting, fan speed setting, sleeping mode setting, follow me setting, it will quit the forced operation.

9.4.7 Economy function

9.4.7.1 The sleep function is available in cooling, heating or auto mode.

9.4.7.2. Operation process in sleep mode is as follow:

When cooling, the setting temperature rises 1°C (be lower than 30°C) every one hour, 2 hours later the setting temperature stops rising and the indoor fan is fixed at low speed.

When heating, the setting temperature decreases 1°C (be higher than 17°C) every one hour, 2 hours later the setting temperature stops rising and indoor fan is fixed at low speed. (Anti-cold wind function has the priority).

9.4.7.3 Operation time in sleep mode is 7 hours. After 7 hours the AC quits this mode and turns off.

9.4.7.4 Timer setting is available

9.4.8 Auto-Restart function

The indoor unit is equipped with auto-restart function, which is carried out through an auto-restart module. In case of a sudden power failure, the module memorizes the setting conditions before the power failure. The unit will resume the previous operation setting (not including swing function) automatically after 3 minutes when power returns.

If the memorization condition is forced cooling mode, the unit will run in cooling mode for 30 minutes and turn to auto mode as 24°C setting temp.

If AC is off before power off and AC is required to start up now, the compressor will have 1 minute delay when power on. Other conditions, the compressor will have 3 minutes delay when restarts.

9.4.9 Refrigerant Leakage Detection

With this new technology, the display area will show “EC” when the outdoor unit detects refrigerant leakage.

9.4.10 8°C Heating (optional)

In heating operation, the preset temperature of the air conditioner can be as lower as 8°C, which keeps the room temperature steady at 8°C and prevents household things freezing when the house is unoccupied for a long time in severe cold weather.

9.4.11 Self clean (optional)

For heat pump models which are provided with this function, after running in cooling or drying mode, if the user press “Self Clean” button on remote controller, firstly, indoor unit runs in fan only mode for a while, then low heat operation and finally runs in fan only again. This function can keep the inside of indoor unit dry and prevent breeding of mold.

9.4.12 Follow me (optional)

- 1) If the indoor PCB receives the signal which results from pressing the FOLLOW ME button on remote controller, the buzzer will emit a sound and this indicates the follow me function is initiated. But when the indoor PCB receives signal which sent from remote controller every 3 minutes, the buzzer will not respond. When the unit is running with follow me function, the PCB will control the unit according to the temperature from follow me signal, and the temperature collection function of room temperature sensor will be shielded, but the error detective function of room temperature sensor will be still valid.
- 2) When the follow me function is available, the PCB will control the unit according to the room temperature from the remote controller and the setting temperature.
- 3) The PCB will take action to the mode change information from remote controller signal, but it will not affected by the setting temperature.
- 4) When the unit is running with follow me function, if the PCB doesn't receive any signal from remote controller for 7 minutes or pressing

FOLLOW ME button again, the follow me function will be turned off automatically, and the temperature will control the unit according to the room temperature detected from its own room temperature sensor and setting temperature.

frequency will keep lower than F2 and the indoor unit will bring faint breeze, which will reduce the noise to the lowest level and create a quiet and comfortable room for you.

9.4.13 Silence operation (optional)

Press the “silence” button on remote controller to initiate SILENCE function. When the Silence function is activated, the compressor running

9.4.14 Point check function

Press the LED DISPLAY or LED or MUTE button of the remote controller three times, and then press the AIR DIRECTION or SWING button three times in ten seconds, the buzzer will keep ring for two seconds.

The air conditioner will enter into the information enquiry status. You can press the LED DISPLAY or AIR DIRECTION button to check the next or front item’s information within 27 seconds.

When the AC enter the “information enquiry” status, it will display the code name in 2 seconds, the details are as follows.

Enquiry information	Displaying code	Meaning
T1	T1	T1 temp.
T2	T2	T2 temp.
T3	T3	T3 temp.
T4	T4	T4 temp.
T2B	Tb	T2B temp.
TP	TP	TP temp.
TH	TH	TH temp.
Targeted Frequency	FT	Targeted Frequency
Actual Frequency	Fr	Actual Frequency
Indoor fan speed	IF	Indoor fan speed
Outdoor fan speed	OF	Outdoor fan speed
EXV opening angle	LA	EXV opening angle
Compressor continuous running time	CT	Compressor continuous running time
Causes of compressor stop.	ST	Causes of compressor stop.
Reserve	A0	
Reserve	A1	
Reserve	b0	
Reserve	b1	
Reserve	b2	
Reserve	b3	
Reserve	b4	
Reserve	b5	
Reserve	b6	

ELECTRONIC FUNCTION

Reserve	dL	
Reserve	Ac	
Reserve	Uo	
Reserve	Td	
Reserve	dA	
Reserve	dS	
Reserve	dT	

When the AC enter into the information enquiry status, it will display the code value in the next 25s, the details are as follows.

Enquiry information	Display value	Meaning	Remark
T1,T2,T3,T4, T2B,TP,TH, Targeted Frequency, Actual Frequency	-1F,-1E,-1d,-1c,- 1b,-1A	-25,-24,-23,-22,-21,-20	1. All the displaying temperature is actual value. 2. All the temperature is °C no matter what kind of remote controller is used. 3. T1,T2,T3,T4,T2B display range:-25~70, TP display range:-20~130. 4. Frequency display range: 0~159HZ. 5. If the actual value exceeds the range, it will display the maximum value or minimum value.
	-19—99	-19—99	
	A0,A1,...A9	100,101,...109	
	b0,b1,...b9	110,111,...119	
	c0,c1,...c9	120,121,...129	
	d0,d1,...d9	130,131,...139	
	E0,E1,...E9	140,141,...149	
	F0,F1,...F9	150,151,...159	
Indoor fan speed /Outdoor fan speed	0	OFF	
	1,2,3,4	Low speed, Medium speed, High speed, Turbo	For some big capacity motors.
	14-FF	Actual fan speed=Display value turns to decimal value and then multiply 10. The unit is RPM.	For some small capacity motors, display value is from 14-FF(hexadecimal), the corresponding fan speed range is from 200-2550RPM.
EXV opening angle	0-FF	Actual EXV opening value=Display value turns to decimal value and then multiply 2.	
Compressor continuous running time	0-FF	0-255 minutes	If the actual value exceeds the range, it will display the maximum value or minimum value.
Causes of compressor stop.	0-99	For the detailed meaning, please consult with engineer	Decimal display
Reserve	0-FF		
Reserve	2~28		
Reserve	5~20		
Reserve	5~25		

10. Troubleshooting

Safety

Electricity power is still kept in capacitors even the power supply is shut off. Do not forget to discharge the electricity power in capacitor.

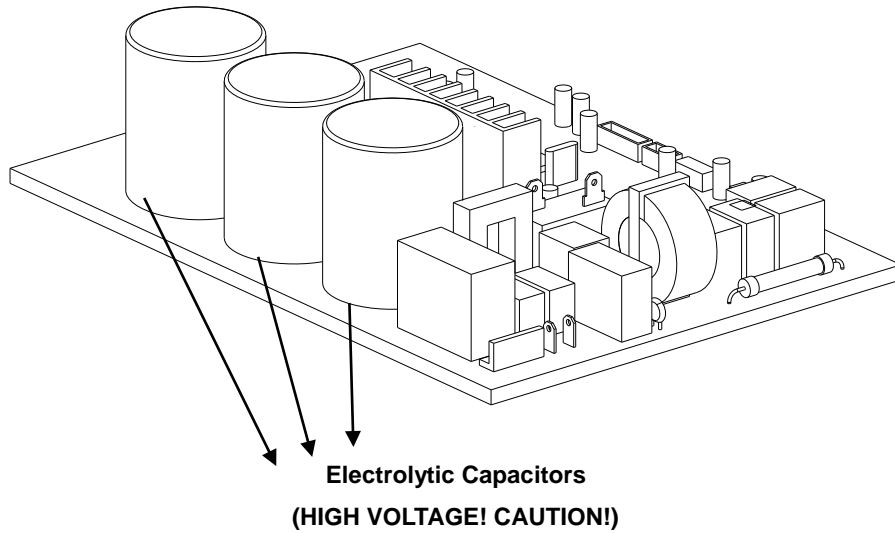

For other models, please connect discharge resistance (approx.100Ω 40W) or soldering iron (plug) between +, - terminals of the electrolytic capacitor on the contrary side of the outdoor PCB.

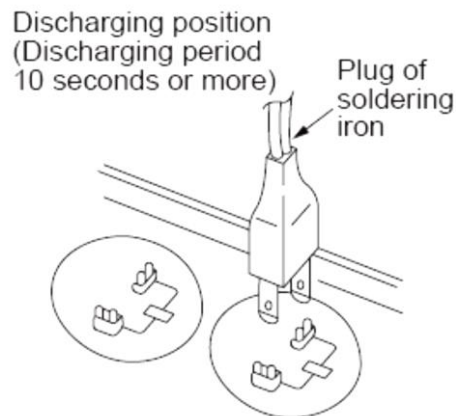

Note: The picture above is only for reference. The plug of your side may be different.

TROUBLESHOOTING

10.1 Indoor Unit Error Display

Operation lamp	Timer lamp	Display	LED STATUS
☆ 1 time	X	E0	Indoor unit EEPROM parameter error
☆ 2 times	X	E1	Indoor / outdoor units communication error
☆ 4 times	X	E3	Indoor fan speed has been out of control
☆ 5 times	X	E4	Indoor room temperature sensor T1 open circuit or short circuit
☆ 6 times	X	E5	Evaporator coil temperature sensor T2 open circuit or short circuit
☆ 7 times	X	EC	Refrigerant leakage detection
☆ 1 times	O	F0	Overload current protection
☆ 2 times	O	F1	Outdoor ambient temperature sensor T4 open circuit or short circuit
☆ 3 times	O	F2	Condenser coil temperature sensor T3 open circuit or short circuit
☆ 4 times	O	F3	Compressor discharge temperature sensor T5 open circuit or short circuit
☆ 5 times	O	F4	Outdoor unit EEPROM parameter error
☆ 6 times	O	F5	Outdoor fan speed has been out of control
☆ 1 times	☆	P0	IPM malfunction or IGBT over-strong current protection
☆ 2 times	☆	P1	Over voltage or over low voltage protection
☆ 3 times	☆	P2	High temperature protection of IPM module or compressor top
☆ 5 times	☆	P4	Inverter compressor drive error

O (light) X (off) ☆ (flash)

*** Fault Symptom:** The display board shows a garbled code or a code that is not an error code found in the service manual nor a temperature reading.

Trouble shooting:

Use the remote controller. If the unit does not respond to the remote, the indoor PCB needs to be replaced; if the unit does respond, then the display board needs to be replaced.

10.2 Trouble shooting

10.2.1 EEPROM parameter error diagnosis and solution(E0/F4)

Error Code	E0/F4
Malfunction decision conditions	Indoor or outdoor PCB main chip does not receive feedback from EEPROM chip.
Supposed causes	<ul style="list-style-type: none"> ● Installation mistake ● PCB faulty

Trouble shooting:

Power off, then restart the unit 2 minutes later.

Yes

Replace the indoor/outdoor main PCB.

EEPROM: a read-only memory whose contents can be erased and reprogrammed using a pulsed voltage. For the location of EEPROM chip, please refer to the below photos.

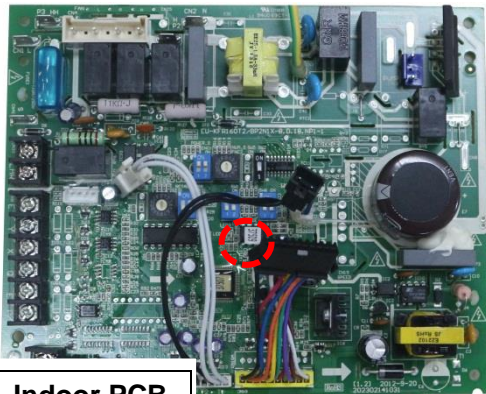

Indoor PCB

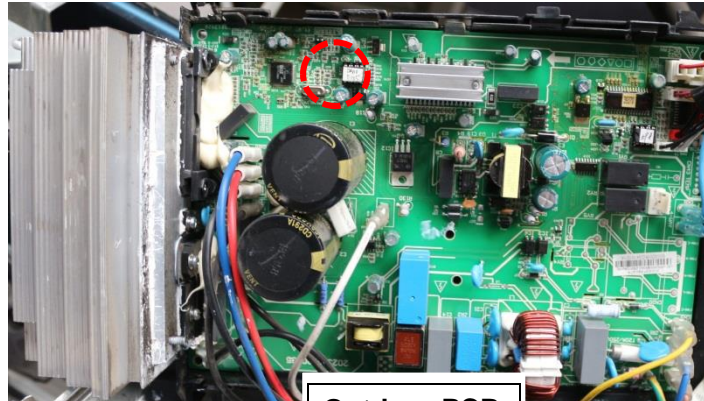

Outdoor PCB

Note: The two photos above are only for reference, it's may be not same totally with the ones on your side.

10.2.2 Indoor / outdoor unit's communication diagnosis and solution (E1)

Error Code	E1
Malfunction decision conditions	Indoor unit does not receive the feedback from outdoor unit during 110 seconds and this condition happens four times continuously.
Supposed causes	<ul style="list-style-type: none"> ● Wiring mistake ● Indoor or outdoor PCB faulty

Trouble shooting:

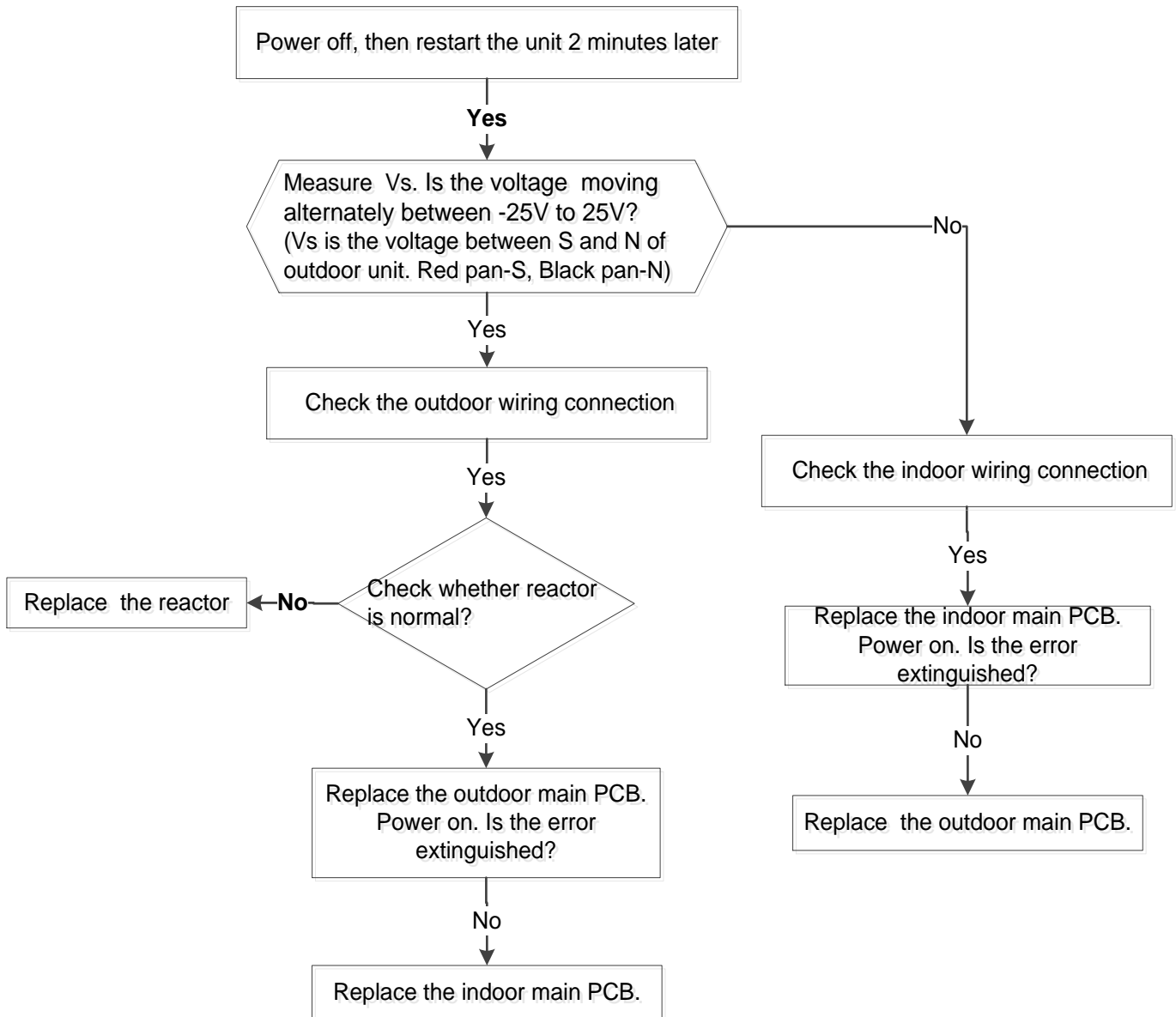

**Remark:**

Use a multi meter to test the resistance of the reactor which does not connect with capacitor.

The normal value should be around zero ohm. Otherwise, the reactor must have malfunction and need to be

TROUBLESHOOTING

10.2.3 Fan speed has been out of control diagnosis and solution(E3)

Error Code	E3/F5
Malfunction decision conditions	When indoor fan speed keeps too low (300RPM) for certain time, the unit will stop and the LED will display the failure.
Supposed causes	<ul style="list-style-type: none"> ● Wiring mistake ● Fan ass'y faulty ● Fan motor faulty ● PCB faulty

Trouble shooting:

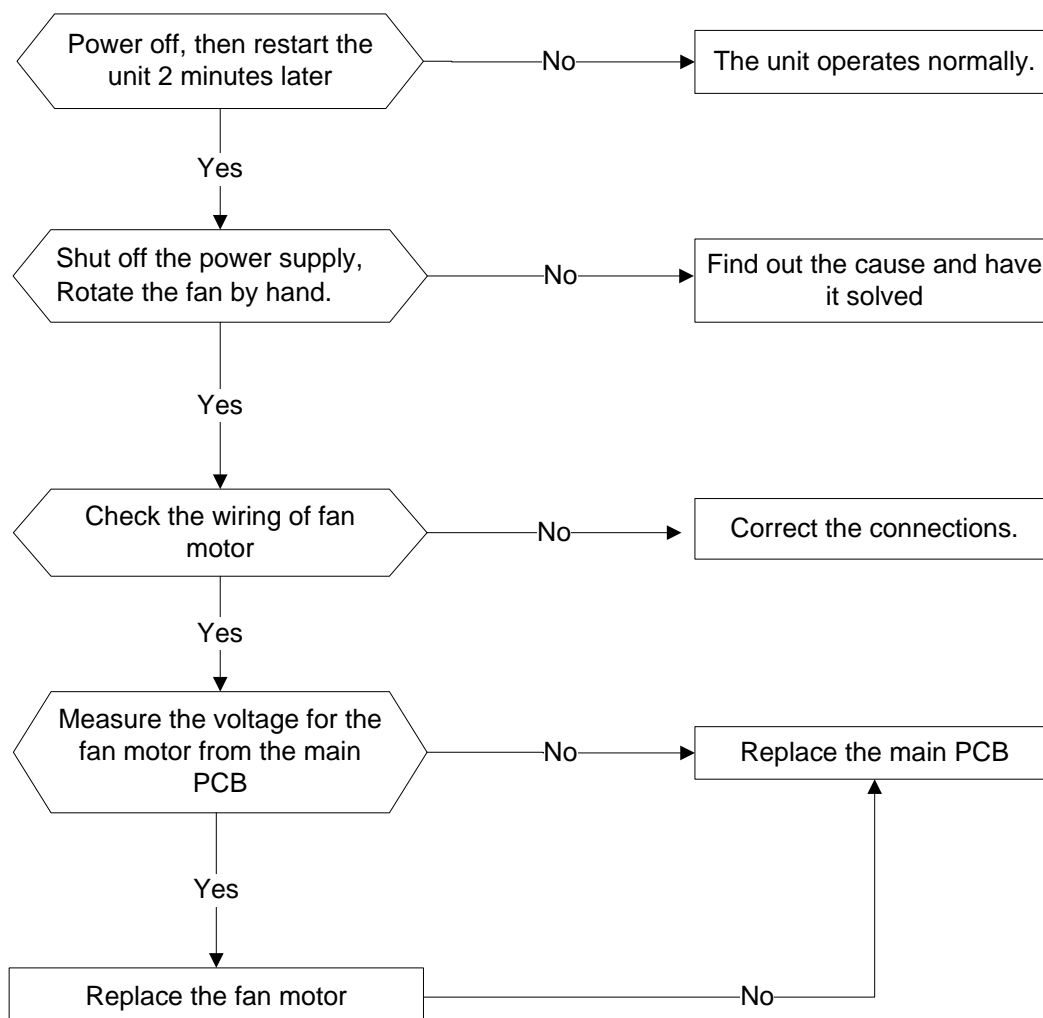

Index1:

1:Indoor or Outdoor DC Fan Motor(control chip is in fan motor)

Power on and when the unit is in standby, measure the voltage of pin1-pin3, pin4-pin3 in fan motor connector. If the value of the voltage is not in the range showing in below table, the PCB must has problems and need to be replaced.

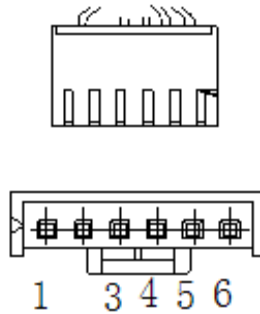

DC motor voltage input and output

NO.	Color	Signal	Voltage
1	Red	Vs/Vm	280V~380V
2	---	---	---
3	Black	GND	0V
4	White	Vcc	14-17.5V
5	Yellow	Vsp	0~5.6V
6	Blue	FG	14-17.5V

2. Outdoor DC Fan Motor (control chip is in outdoor PCB)

Power on ,and check if the fan can run normally, if the fan can run normally, the PCB must has problems and need to be replaced, If the fan can't run normally, measure the resistance of each two pins. If the resistance is not equal to each other, the fan motor must have problems and need to be replaced, otherwise the PCB must has problems and need to be replaced.

3. Indoor AC Fan Motor

Power on and set the unit running in fan mode at high fan speed. After running for 15 seconds, measure the voltage of pin1 and pin2. If the value of the voltage is less than 100V(208~240V power supply)or 50V(115V power supply), the PCB must has problems and need to be replaced.

10.2.4 Refrigerant Leakage Detection diagnosis and solution(EC)

Error Code	EC
Malfunction decision conditions	<p>Define the evaporator coil temp.T2 of the compressor just starts running as Tcool.</p> <p>In the beginning 8 minutes after the compressor starts up, if $T2 < T_{cool} - 2^{\circ}C$ does not keep continuous 4 seconds and compressor running frequency higher than 50Hz does not keep continuous 3 minutes, and this situation happens 3 times, the display area will show “EC” and AC will turn off.</p>
Supposed causes	<ul style="list-style-type: none"> ● T2 sensor faulty ● Indoor PCB faulty ● System problems, such as leakage or blocking.

Trouble shooting:

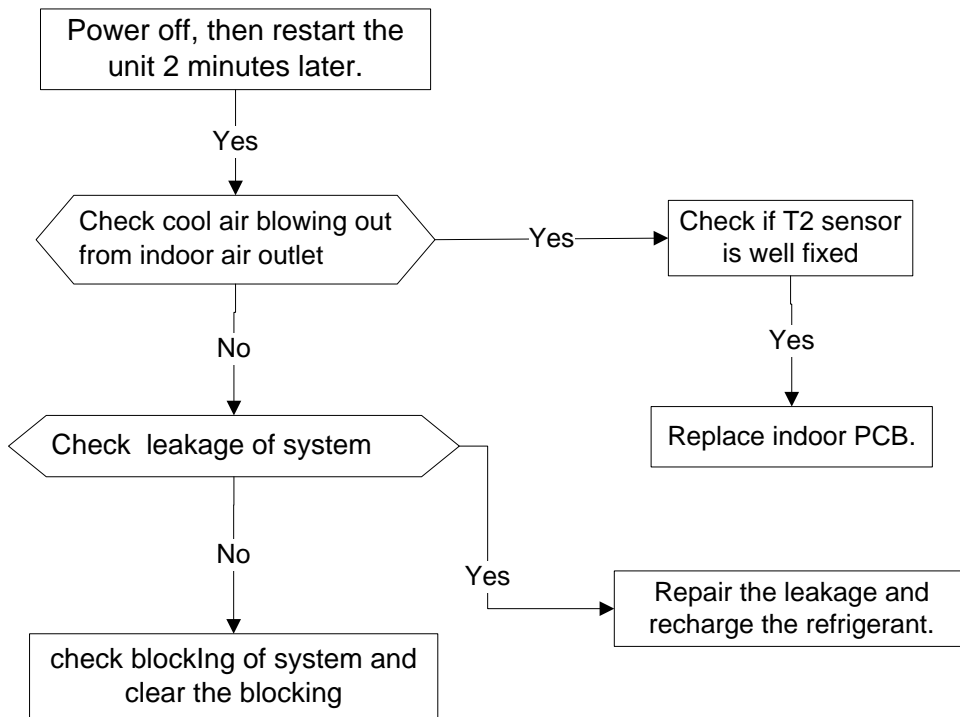

10.2.5 Open circuit or short circuit of temperature sensor diagnosis and solution (E5)

Error Code	E4/E5/F1/F2/F3
Malfunction decision conditions	If the sampling voltage is lower than 0.06V or higher than 4.94V, the LED will display the failure.
Supposed causes	<ul style="list-style-type: none"> • Wiring mistake • Sensor faulty • PCB faulty

Trouble shooting:

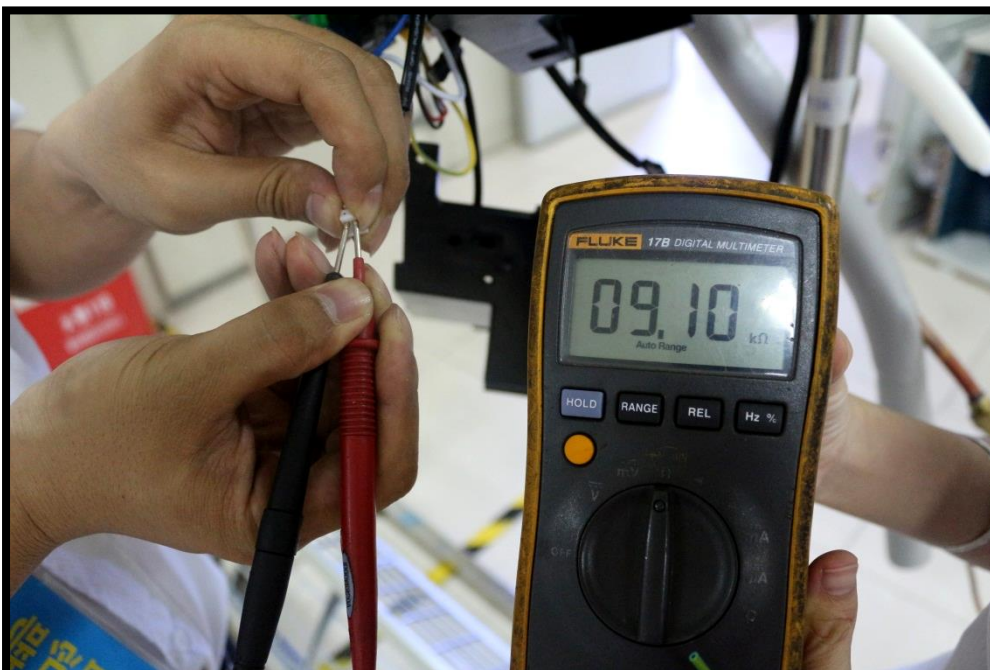
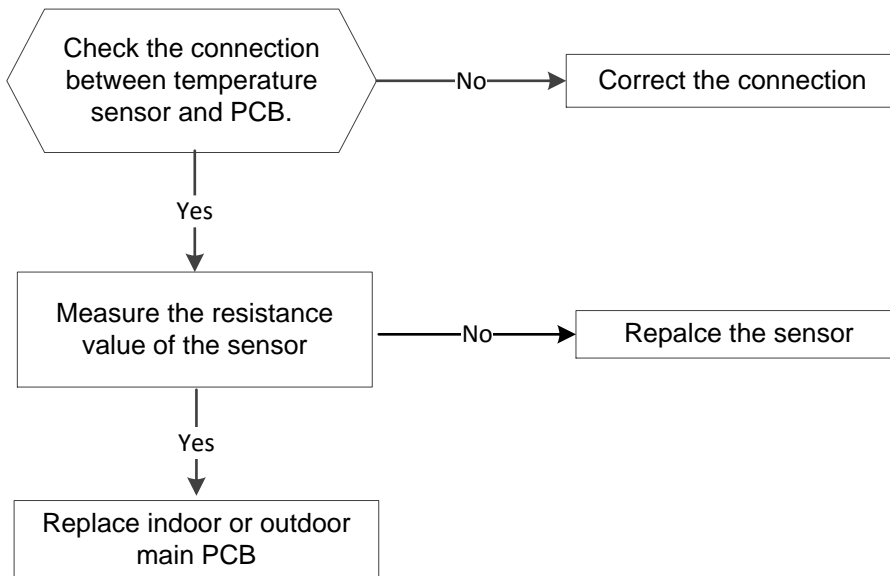

10.2.6 Overload current protection diagnosis and solution(F0)

Error Code	F0
Malfunction decision conditions	An abnormal current rise is detected by checking the specified current detection circuit.
Supposed causes	<ul style="list-style-type: none"> ● Power supply problems. ● System blockage ● PCB faulty ● Wiring mistake ● Compressor malfunction

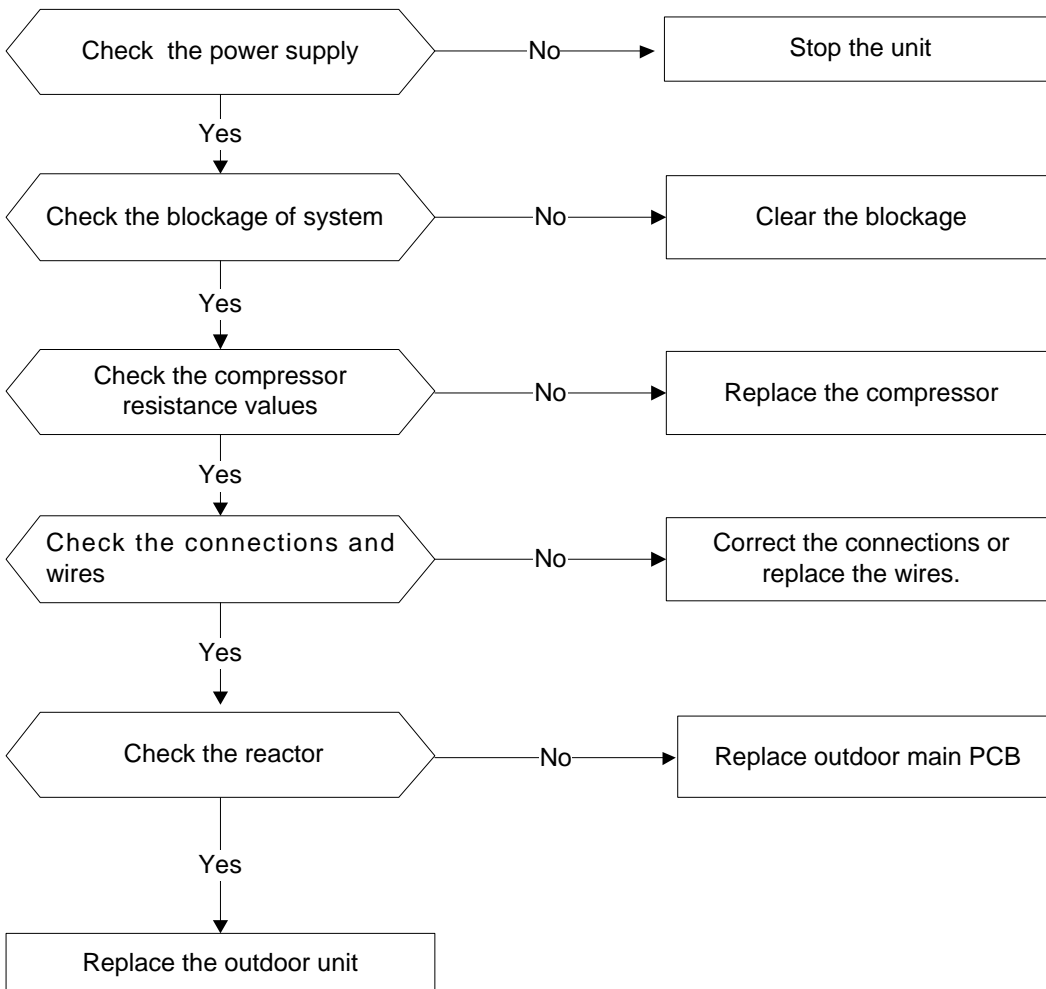

10.2.7 IPM malfunction or IGBT over-strong current protection diagnosis and solution (P0)

Error Code	P0
Malfunction decision conditions	When the voltage signal that IPM send to compressor drive chip is abnormal, the display LED will show “P0” and AC will turn off.
Supposed causes	<ul style="list-style-type: none"> ● Wiring mistake ● IPM malfunction ● Outdoor fan ass’y faulty ● Compressor malfunction ● Outdoor PCB faulty

Trouble shooting:

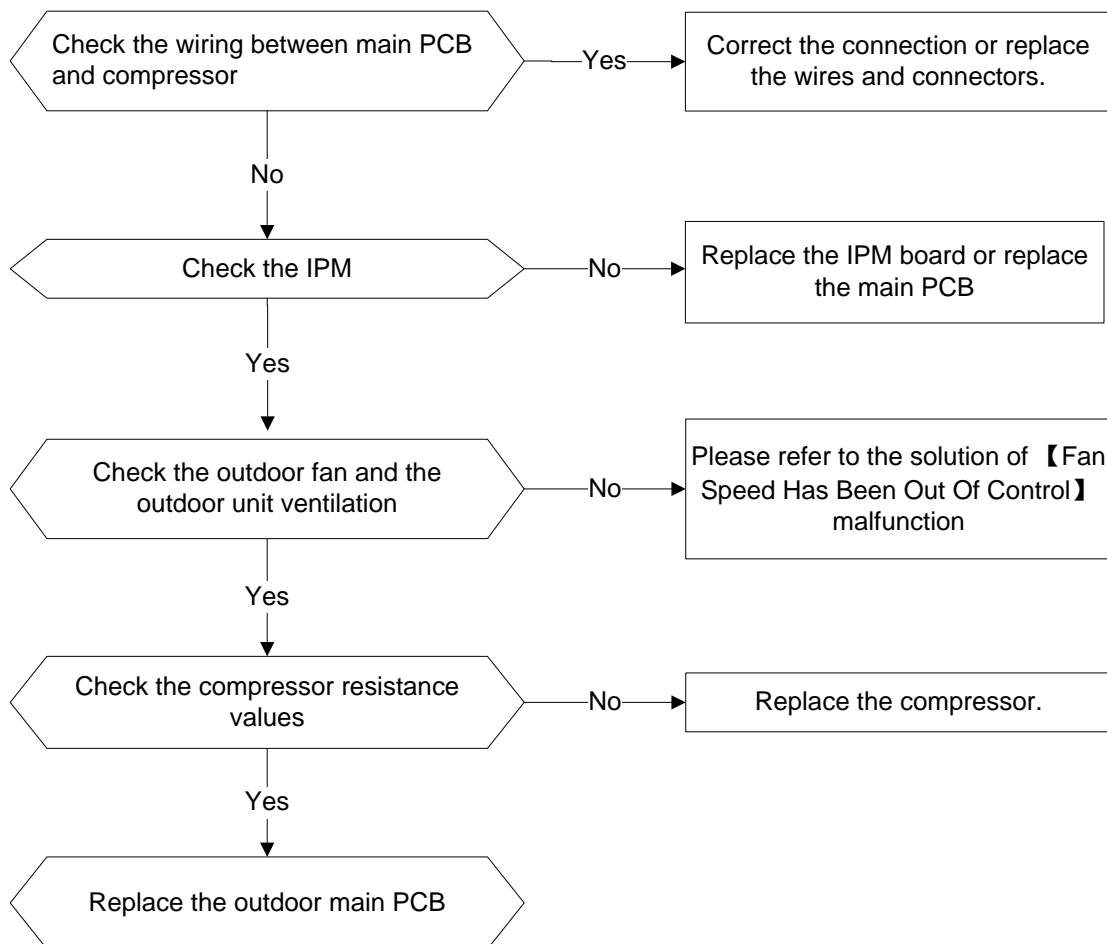

➤ **IPM continuity check**

Turn off the power, let the large capacity electrolytic capacitors discharge completely, and dismount the IPM. Use a digital tester to measure the resistance between P and UVWN; UVW and N.

Digital tester		Normal resistance value	Digital tester		Normal resistance value
(+)Red	(-)Black		(+)Red	(-)Black	
P	N	∞ (Several MΩ)	U	N	∞ (Several MΩ)
	U				
	V				
	W				
	(+)Red		(-)Black		

10.2.8 Over voltage or too low voltage protection diagnosis and solution (P1)

Error Code	P1
Malfunction decision conditions	An abnormal voltage rise or drop is detected by checking the specified voltage detection circuit.
Supposed causes	<ul style="list-style-type: none"> ● Power supply problems. ● System leakage or block ● PCB faulty

Trouble shooting:

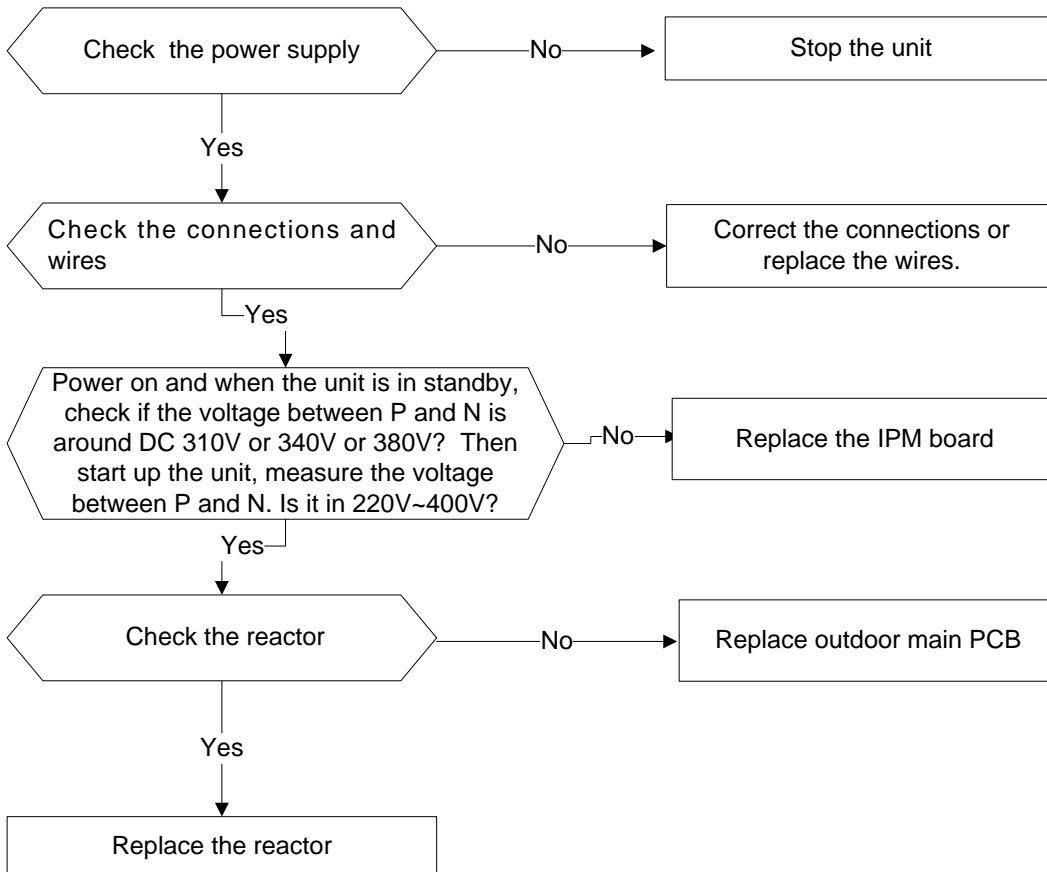

10.2.9 High temperature protection of IPM module or compressor top diagnosis and solution(P2)

Error Code	P2
Malfunction decision conditions	If the sampling voltage is not 5V, the LED will display the failure.
Supposed causes	<ul style="list-style-type: none"> ● Installation mistake ● Power supply problems. ● System leakage or block ● PCB faulty

Trouble shooting:

For 24K,

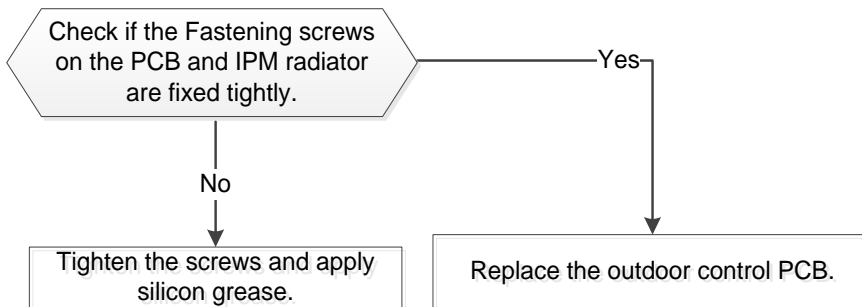

For other models,

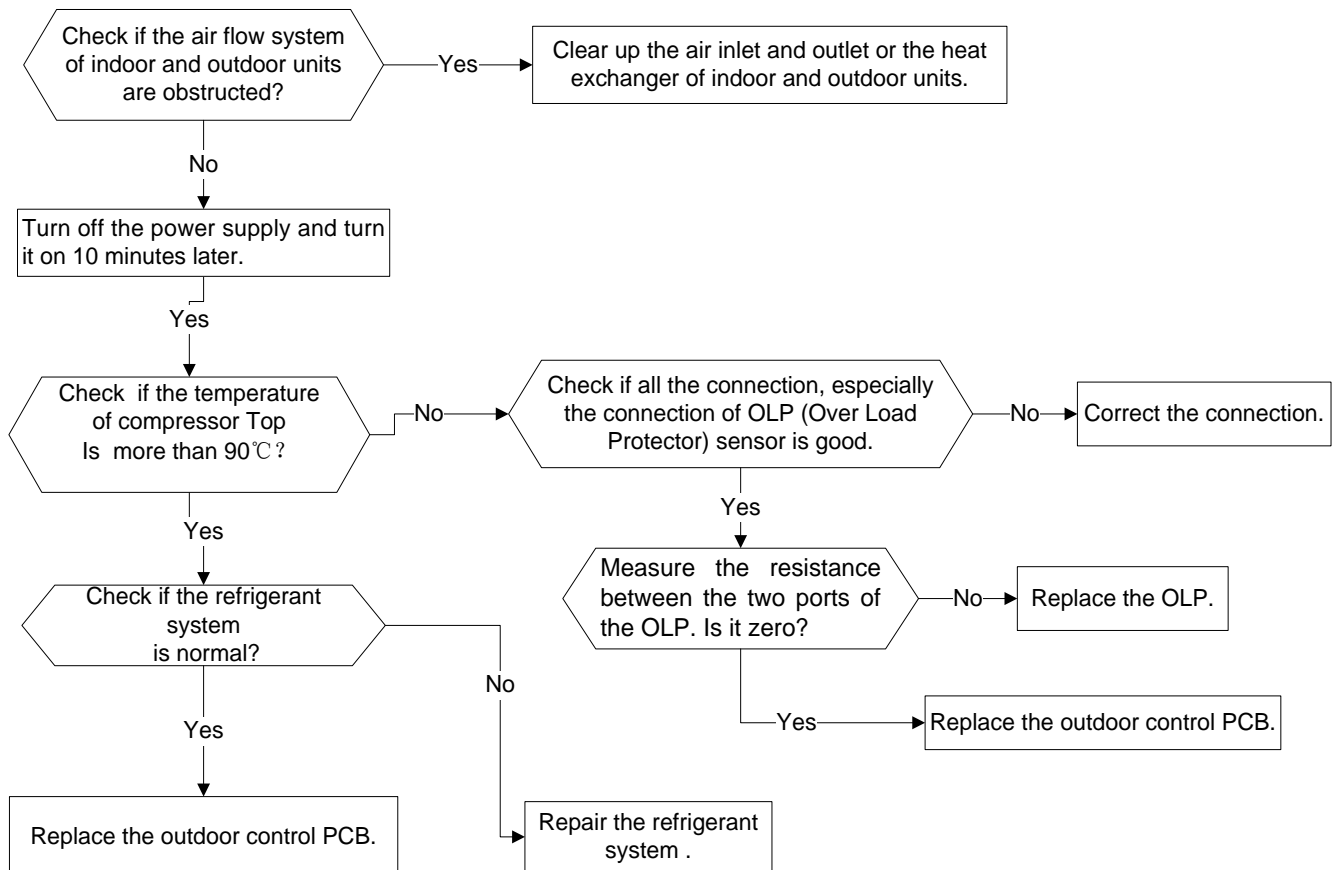

10.2.10 Inverter compressor drive error diagnosis and solution (P4)

Error Code	P4
Malfunction decision conditions	An abnormal inverter compressor drive is detected by a special detection circuit, including communication signal detection, voltage detection, compressor rotation speed signal detection and so on.
Supposed causes	<ul style="list-style-type: none"> ● Wiring mistake ● IPM malfunction ● Outdoor fan ass'y faulty ● Compressor malfunction ● Outdoor PCB faulty

Trouble shooting:

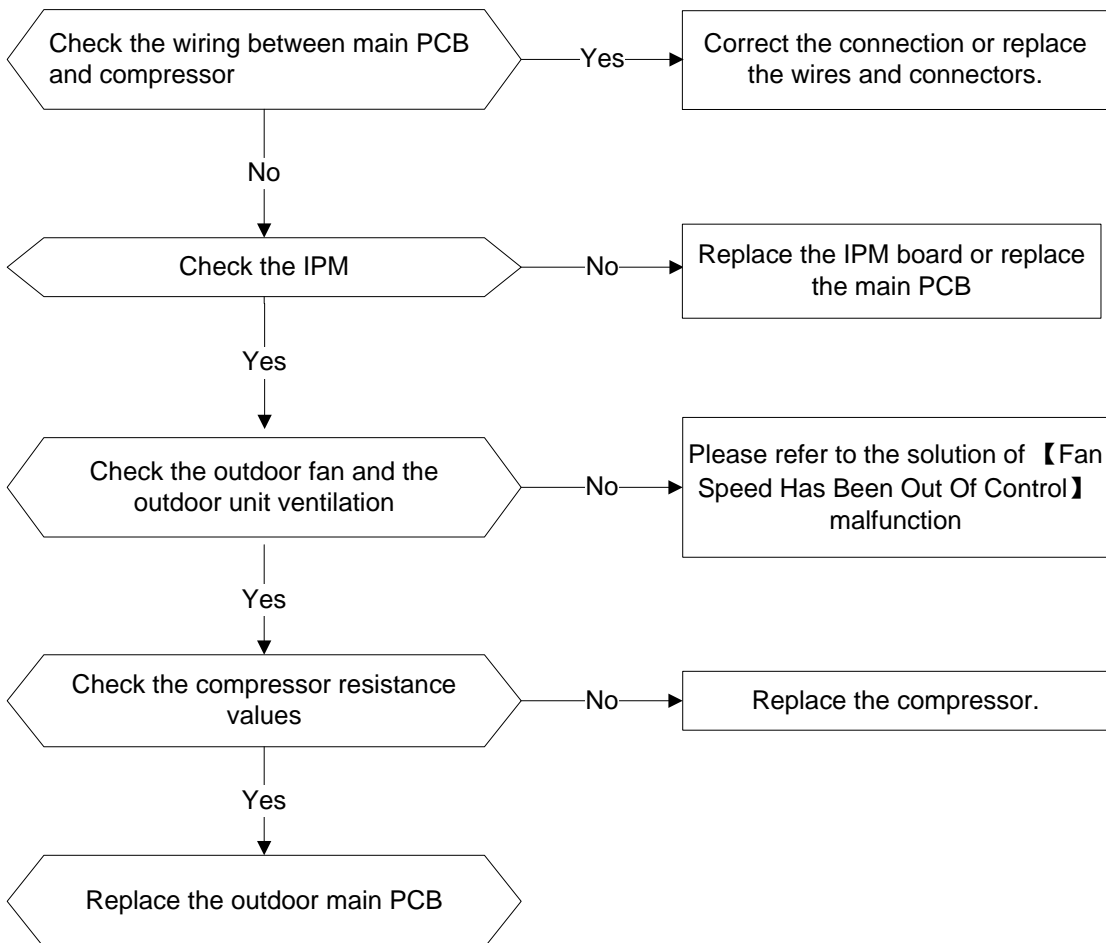

Main parts check**1. Temperature sensor checking**

Disconnect the temperature sensor from PCB, measure the resistance value with a tester.

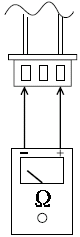

Tester

Temperature Sensors.

Room temp.(T1) sensor,

Indoor coil temp.(T2) sensor,

Outdoor coil temp.(T3) sensor,

Outdoor ambient temp.(T4) sensor,

Compressor discharge temp.(T5) sensor.

Measure the resistance value of each winding by using the multi-meter.

TROUBLESHOOTING
Appendix 1 Temperature Sensor Resistance Value Table for T1,T2,T3,T4 (°C--K)

°C	°F	K Ohm	°C	°F	K Ohm	°C	°F	K Ohm	°C	°F	K Ohm
-20	-4	115.266	20	68	12.6431	60	140	2.35774	100	212	0.62973
-19	-2	108.146	21	70	12.0561	61	142	2.27249	101	214	0.61148
-18	0	101.517	22	72	11.5	62	144	2.19073	102	216	0.59386
-17	1	96.3423	23	73	10.9731	63	145	2.11241	103	217	0.57683
-16	3	89.5865	24	75	10.4736	64	147	2.03732	104	219	0.56038
-15	5	84.219	25	77	10	65	149	1.96532	105	221	0.54448
-14	7	79.311	26	79	9.55074	66	151	1.89627	106	223	0.52912
-13	9	74.536	27	81	9.12445	67	153	1.83003	107	225	0.51426
-12	10	70.1698	28	82	8.71983	68	154	1.76647	108	226	0.49989
-11	12	66.0898	29	84	8.33566	69	156	1.70547	109	228	0.486
-10	14	62.2756	30	86	7.97078	70	158	1.64691	110	230	0.47256
-9	16	58.7079	31	88	7.62411	71	160	1.59068	111	232	0.45957
-8	18	56.3694	32	90	7.29464	72	162	1.53668	112	234	0.44699
-7	19	52.2438	33	91	6.98142	73	163	1.48481	113	235	0.43482
-6	21	49.3161	34	93	6.68355	74	165	1.43498	114	237	0.42304
-5	23	46.5725	35	95	6.40021	75	167	1.38703	115	239	0.41164
-4	25	44	36	97	6.13059	76	169	1.34105	116	241	0.4006
-3	27	41.5878	37	99	5.87359	77	171	1.29078	117	243	0.38991
-2	28	39.8239	38	100	5.62961	78	172	1.25423	118	244	0.37956
-1	30	37.1988	39	102	5.39689	79	174	1.2133	119	246	0.36954
0	32	35.2024	40	104	5.17519	80	176	1.17393	120	248	0.35982
1	34	33.3269	41	106	4.96392	81	178	1.13604	121	250	0.35042
2	36	31.5635	42	108	4.76253	82	180	1.09958	122	252	0.3413
3	37	29.9058	43	109	4.5705	83	181	1.06448	123	253	0.33246
4	39	28.3459	44	111	4.38736	84	183	1.03069	124	255	0.3239
5	41	26.8778	45	113	4.21263	85	185	0.99815	125	257	0.31559
6	43	25.4954	46	115	4.04589	86	187	0.96681	126	259	0.30754
7	45	24.1932	47	117	3.88673	87	189	0.93662	127	261	0.29974
8	46	22.5662	48	118	3.73476	88	190	0.90753	128	262	0.29216
9	48	21.8094	49	120	3.58962	89	192	0.8795	129	264	0.28482
10	50	20.7184	50	122	3.45097	90	194	0.85248	130	266	0.2777
11	52	19.6891	51	124	3.31847	91	196	0.82643	131	268	0.27078
12	54	18.7177	52	126	3.19183	92	198	0.80132	132	270	0.26408
13	55	17.8005	53	127	3.07075	93	199	0.77709	133	271	0.25757
14	57	16.9341	54	129	2.95896	94	201	0.75373	134	273	0.25125
15	59	16.1156	55	131	2.84421	95	203	0.73119	135	275	0.24512
16	61	15.3418	56	133	2.73823	96	205	0.70944	136	277	0.23916
17	63	14.6181	57	135	2.63682	97	207	0.68844	137	279	0.23338
18	64	13.918	58	136	2.53973	98	208	0.66818	138	280	0.22776
19	66	13.2631	59	138	2.44677	99	210	0.64862	139	282	0.22231

Appendix 2 Temperature Sensor Resistance Value Table for T5 (°C --K)

°C	°F	K Ohm	°C	°F	K Ohm	°C	°F	K Ohm	°C	°F	K Ohm
-20	-4	542.7	20	68	68.66	60	140	13.59	100	212	3.702
-19	-2	511.9	21	70	65.62	61	142	13.11	101	214	3.595
-18	0	483	22	72	62.73	62	144	12.65	102	216	3.492
-17	1	455.9	23	73	59.98	63	145	12.21	103	217	3.392
-16	3	430.5	24	75	57.37	64	147	11.79	104	219	3.296
-15	5	406.7	25	77	54.89	65	149	11.38	105	221	3.203
-14	7	384.3	26	79	52.53	66	151	10.99	106	223	3.113
-13	9	363.3	27	81	50.28	67	153	10.61	107	225	3.025
-12	10	343.6	28	82	48.14	68	154	10.25	108	226	2.941
-11	12	325.1	29	84	46.11	69	156	9.902	109	228	2.86
-10	14	307.7	30	86	44.17	70	158	9.569	110	230	2.781
-9	16	291.3	31	88	42.33	71	160	9.248	111	232	2.704
-8	18	275.9	32	90	40.57	72	162	8.94	112	234	2.63
-7	19	261.4	33	91	38.89	73	163	8.643	113	235	2.559
-6	21	247.8	34	93	37.3	74	165	8.358	114	237	2.489
-5	23	234.9	35	95	35.78	75	167	8.084	115	239	2.422
-4	25	222.8	36	97	34.32	76	169	7.82	116	241	2.357
-3	27	211.4	37	99	32.94	77	171	7.566	117	243	2.294
-2	28	200.7	38	100	31.62	78	172	7.321	118	244	2.233
-1	30	190.5	39	102	30.36	79	174	7.086	119	246	2.174
0	32	180.9	40	104	29.15	80	176	6.859	120	248	2.117
1	34	171.9	41	106	28	81	178	6.641	121	250	2.061
2	36	163.3	42	108	26.9	82	180	6.43	122	252	2.007
3	37	155.2	43	109	25.86	83	181	6.228	123	253	1.955
4	39	147.6	44	111	24.85	84	183	6.033	124	255	1.905
5	41	140.4	45	113	23.89	85	185	5.844	125	257	1.856
6	43	133.5	46	115	22.89	86	187	5.663	126	259	1.808
7	45	127.1	47	117	22.1	87	189	5.488	127	261	1.762
8	46	121	48	118	21.26	88	190	5.32	128	262	1.717
9	48	115.2	49	120	20.46	89	192	5.157	129	264	1.674
10	50	109.8	50	122	19.69	90	194	5	130	266	1.632
11	52	104.6	51	124	18.96	91	196	4.849			
12	54	99.69	52	126	18.26	92	198	4.703			
13	55	95.05	53	127	17.58	93	199	4.562			
14	57	90.66	54	129	16.94	94	201	4.426			
15	59	86.49	55	131	16.32	95	203	4.294			
16	61	82.54	56	133	15.73	96	205	4.167			
17	63	78.79	57	135	15.16	97	207	4.045			
18	64	75.24	58	136	14.62	98	208	3.927			
19	66	71.86	59	138	14.09	99	210	3.812			

TROUBLESHOOTING

2. Compressor checking

Measure the resistance value of each winding by using the tester.

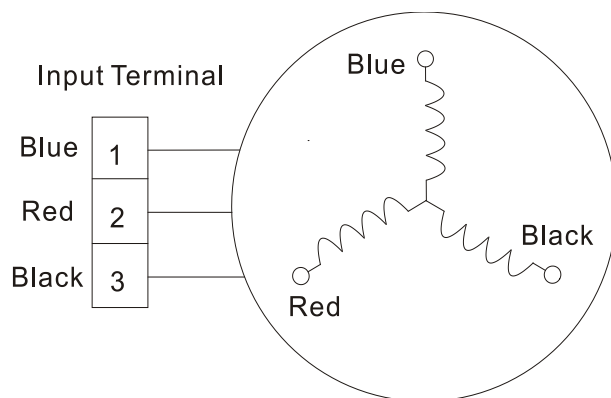

Position	Resistance Value		
	ASK89D53UEZ	ASM135D23UFZ	ATF235D22UMT
Blue - Red	2.35Ω (20°C/68°F)	1.75Ω (20°C/68°F)	0.75Ω (20°C/68°F)
Blue - Black			
Red - Blue			

11. Exploded View and Spare Part List

11.1 Exploded view of model AWSI-HKD009-N11, AWSI-HKD012-N11, AWSI-HKD018-N11

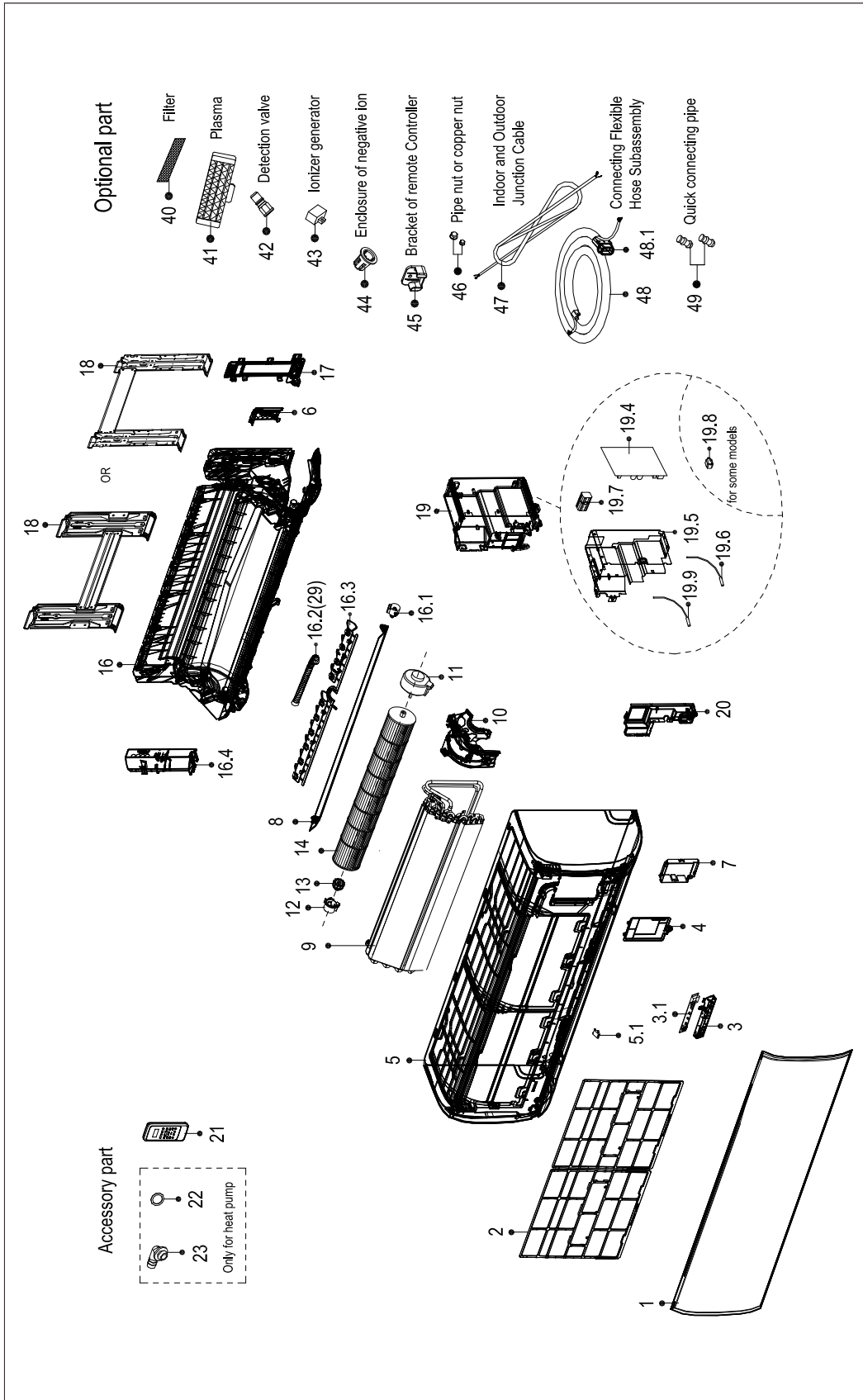

EXPLODED VIEW AND SPARE PART LIST
11.2 Spare part list of model AWSI-HKD009-N11

No.	BOM Code	Part Name	Quantity
1	12122000A49209	Panel assembly	1
2	12122000015223	Air filter	2
3	17222000A45948	Display box assembly	1
3.1	17122000A22268	Display board assembly	1
4	12122000013131	Cover of electrical equipment	1
5	12122000013137	Panel frame assembly	1
5.1	12122000013139	Screw cap	2
6	12122000013140	Right cover of chassis	1
7	12122000013141	Terminal cover assembly	1
8	12122000013127	Horizontal louver assembly	1
9	15822000A13069	Evaporator Assembly	1
10	12122000013129	Fan motor cover	1
11	11002012002778	Single-phase Asynchronous Motor	1
12	12122000000350	beating base jacket	1
13	12622000000006	Beating base	1
14	12100102000156	Cross flow fan	1
16	12122000013121	Chassis assembly	1
16.1	11002010000143	stepper motor	1
16.3	12122000013761	Vertical vane	1
16.4	12122000013123	Left cover of chassis	1
17	12122000013136	Pipe clamp board	1
18	12222000005844	Installation Plate	1
19	17222000A45331	Electronic control box assembly	1
19.4	17122000024362	Indoor Main Control Board Subassembly (Sticker)	1
19.5	12122000013001	Electronic installing box	1
19.6	11201007000322	Temperature Sensor	1
19.7	17400401000576	Wire joint	1
19.9	11201007000088	Room Temperature Sensor	1
20	12122000013132	Cover of electronic control box	1
21	17317000A02580	Remote controller	1
22	12600701000039	Seal ring	1
23	12100509000061	Drain hose	1
29	12100501000032	Drain Hose	1
40	12100204000685	Air freshening filter	1
40	12100207000007	Air freshening filter	1
42	15500209000001	Detection valve	1
45	12117000000086	Mounting bracket of remote controller	1
46	15500404000002	Pipe Nut	1
46	15500406000010	Copper nut	1
46	15500406000016	Copper nut	1

11.3 Spare part list of model: AWSI-HKD012-N11

No.	BOM Code	Part Name	Quantity
1	12122000A49210	Panel assembly	1
2	12122000015224	Air filter	2
3	17222000A45948	Display box assembly	1
3.1	17122000A22268	Display board assembly	1
4	12122000013131	Cover of electrical equipment	1
5	12122000013170	Panel frame assembly	1
5.1	12122000013139	Screw cap	2
6	12122000013140	Right cover of chassis	1
7	12122000013141	Terminal cover assembly	1
8	12122000013168	Wind Guide Assembly	1
9	15822000A11910	Evaporator Assembly	1
10	12122000013129	Fan motor cover	1
11	11002012002778	Single-phase Asynchronous Motor	1
12	12122000000350	beating base jacket	1
13	12622000000006	Beating base	1
14	12100102000044	Cross-flow Window Rotor.	1
16	12122000013163	Chassis assembly	1
16.1	11002010000143	stepper motor	1
16.3	12122000013763	Vertical vane	1
16.4	12122000013123	Left cover of chassis	1
17	12122000013136	Pipe clamp board	1
18	12222000005844	Installation Plate	1
19	17222000A45330	Electronic control box assembly	1
19.4	17122000024360	Indoor Main Control Board Subassembly (Sticker)	1
19.5	12122000013001	Electronic installing box	1
19.6	11201007000322	Temperature Sensor	1
19.7	17400401000576	Wire joint	1
19.9	11201007000088	Room Temperature Sensor	1
20	12122000013132	Cover of electronic control box	1
21	17317000A02580	Remote controller	1
22	12600701000039	Seal ring	1
23	12100509000061	Drain hose	1
29	12100501000032	Drain Hose	1
40	12100204000685	Air freshening filter	1
40	12100207000007	Air freshening filter	1
42	15500209000001	Detection valve	1
45	12117000000086	Mounting bracket of remote controller	1
46	15500404000002	Pipe Nut	1
46	15500406000010	Copper nut	1
46	15500406000016	Copper nut	1

EXPLODED VIEW AND SPARE PART LIST
11.4 Spare part list of model: AWSI-HKD018-N11

No.	BOM Code	Part Name	Quantity
1	12122000A49214	Panel assembly	1
2	12100204001559	Air filter	2
3	17222000A45948	Display box assembly	1
3.1	17122000A22268	Display board assembly	1
4	12122000013131	Cover of electrical equipment	1
5	12122000013179	Panel frame assembly	1
5.1	12122000013139	Screw cap	2
6	12122000013175	Right cover of chassis	1
7	12122000013141	Terminal cover assembly	1
8	12122000013187	Horizontal louver assembly	1
9	15822000004976	Evaporator assembly Gas valve assembly	1
10	12122000013176	Fan motor cover	1
11	11002015000139	Brushless DC Motor	1
12	12122000000350	beating base jacket	1
13	12622000000006	Beating base	1
14	12100102000131	Cross-flow Window Rotor.	1
16	12122000013181	Chassis assembly	1
16.1	11002010000143	stepper motor	1
16.3	12122000013183	Vertical vane	1
16.4	12122000013186	Left cover of chassis	1
17	12122000013178	Pipe clamp board	1
18	12222000005866	Installation plate	1
19	17222000A45329	Electronic control box assembly	1
19.4	17122000024357	Indoor Main Control Board Subassembly (Sticker)	1
19.5	12122000013001	Electronic installing box	1
19.6	11201007000322	Temperature Sensor	1
19.7	17400401000576	Wire joint	1
19.9	11201007000088	Room Temperature Sensor	1
20	12122000013132	Cover of electronic control box	1
21	17317000A02580	Remote controller	1
22	12600701000039	Seal ring	1
23	12100509000061	Drain hose	1
29	12100501000032	Drain Hose	1
40	12100204000685	Air freshening filter	1
40	12100207000007	Air freshening filter	1
42	15500209000001	Detection valve	1
45	12117000000086	Mounting bracket of remote controller	1
46	15500404000009	plastic nut	1
46	15500406000012	Copper nut	1
46	15500406000016	Copper nut	1

11.5 Exploded view of model: AWSI-HKD024-N11

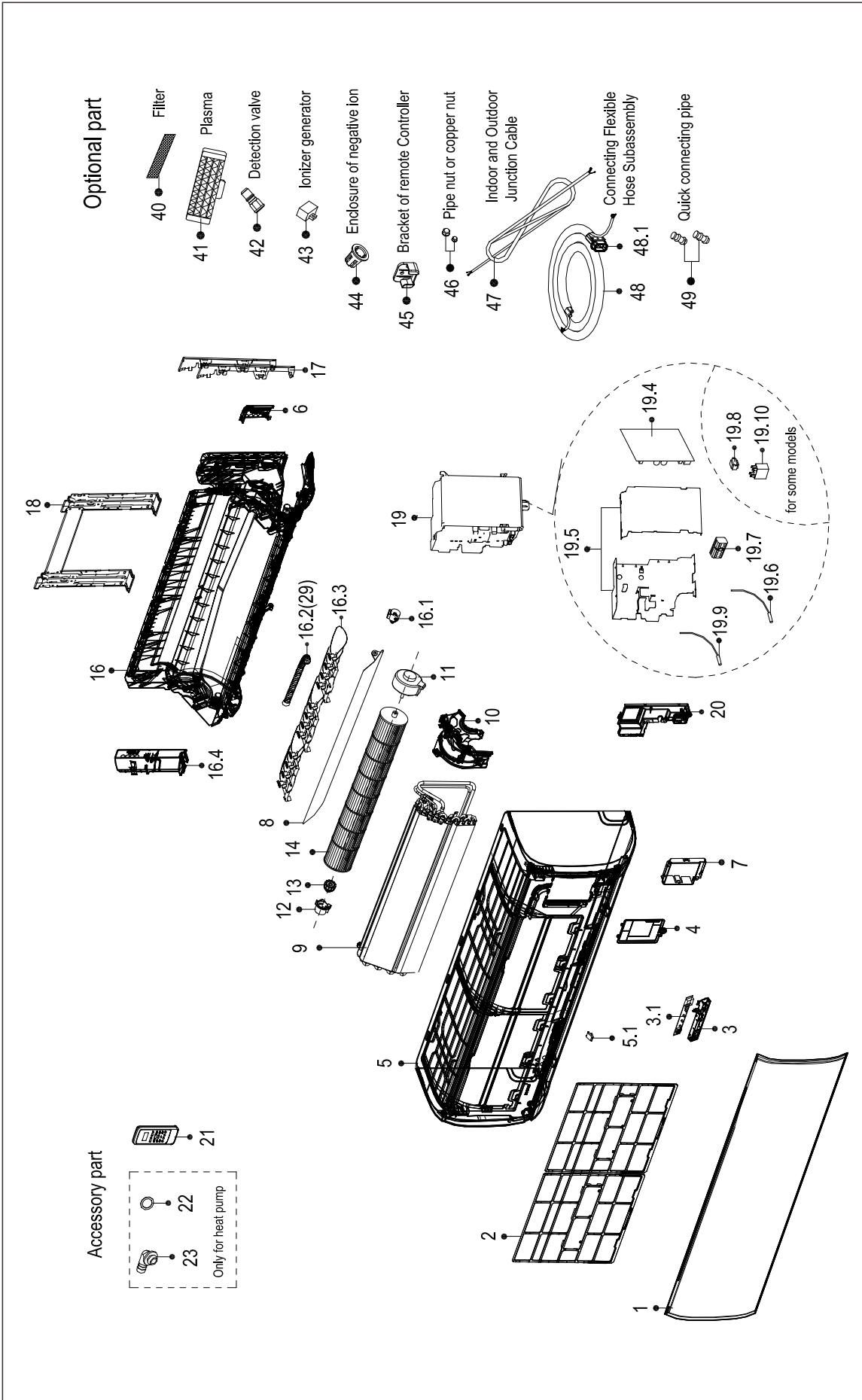

11.6 Spare part list of model: AWSI-HKD024-N11

No.	BOM Code	Part Name	Quantity
1	12122000A49215	Panel assembly	1
2	12122000015222	Air filter	2
3	17222000A45948	Display box assembly	1
3.1	17122000A22268	Display board assembly	1
4	12122000013357	Cover of electrical equipment	1
5	12122000013353	Panel frame assembly	1
5.1	12122000013355	Screw cap	2
7	12122000013350	Terminal cover assembly	1
8	12122000013348	Horizontal louver assembly	1
9	15822000004857	Evaporator assembly Gas valve assembly	1
10	12122000013349	Fan motor cover	1
11	11002015000094	Brushless DC Motor	1
12	12122000000350	beating base jacket	1
13	12622000000006	Beating base	1
14	12100102000002	Cross fan ass'y	1
16	12122000013341	Chassis Assembly	1
16.1	11002010000049	stepper motor	1
16.3	12122000013343	Vertical vane	3
16.4	12122000013342	Left cover of chassis	1
17	12122000013346	Pipe clamp board	1
18	12222000005965	Installation plate	1
19	17222000A45332	Electronic control box assembly	1
19.4	17122000024354	Indoor Main Control Board Subassembly (Sticker)	1
19.5	12122000013004	Electronic installing box	1
19.6	11201007000322	Temperature Sensor	1
19.7	17400401000576	Wire joint	1
19.9	11201007000088	Room Temperature Sensor	1
20	12122000013356	Cover of electronic control box	1
21	17317000A02580	Remote controller	1
22	12600701000039	Seal ring	1
23	12100509000061	Drain hose	1
29	12100501000032	Drain Hose	1
40	12100204000685	Air freshening filter	1
40	12100207000007	Air freshening filter	1
42	15500209000002	detection valve	1
45	12117000000086	Mounting bracket of remote controller	1
46	15500404000005	Pipe Nut	1
46	15500406000003	Copper net	1
46	15500406000010	Copper nut	1

11.7 Exploded view of model AWAU-YKD009-H11, AWAU-YKD012-H11

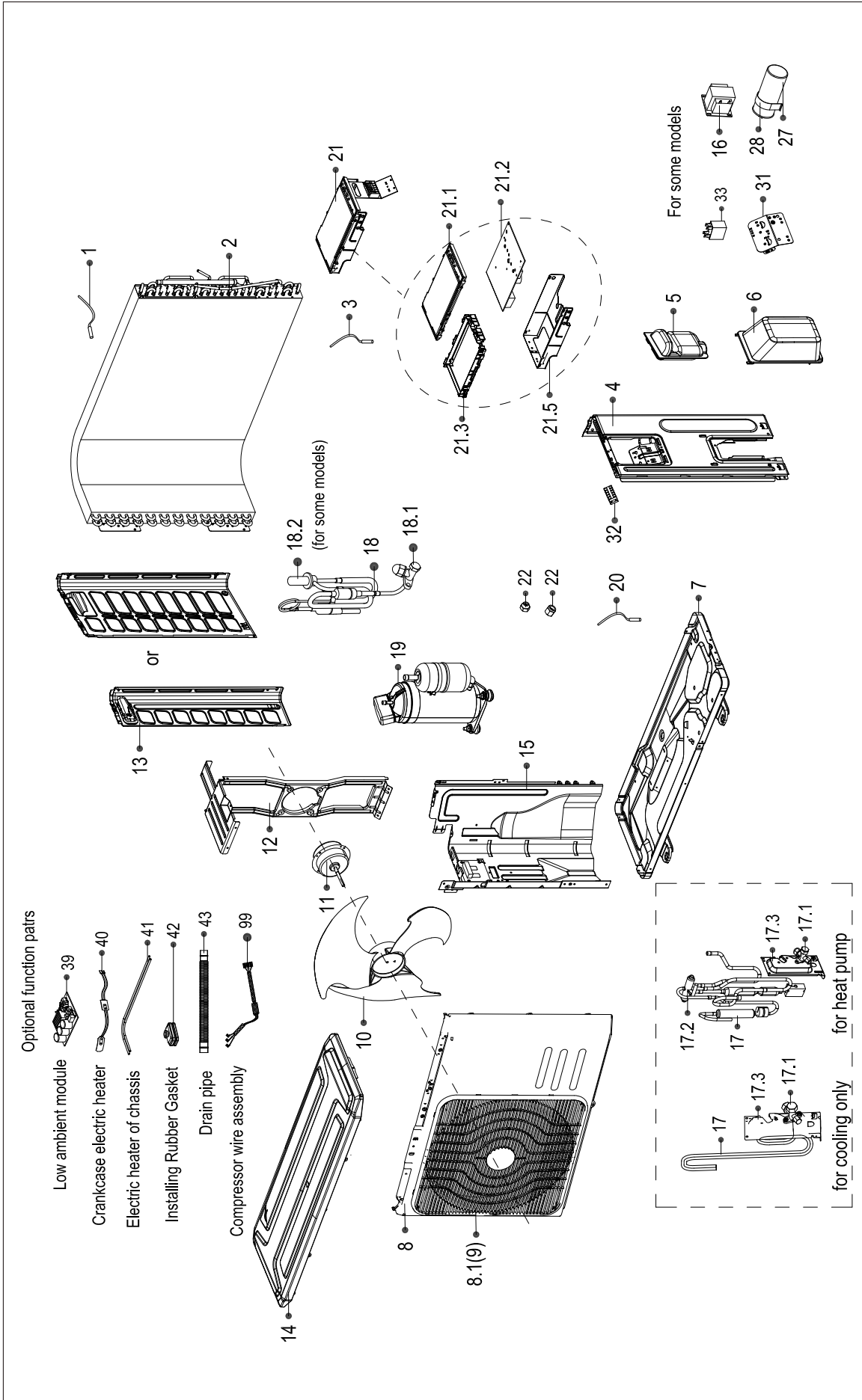

11.8 Spare part list of model AWAU-YKD009-H11

NO.	BOM CODE	PART NAME	QUANTITY
1	11201007002020	Room Temperature Sensor	1
2	15822000003296	Condenser Assembly	1
3	11201007000136	Pipe temperature sensor assembly	1
4	12222000003597	Parts fn Right Side Plate	1
5	12100701000015	Big handle	1
6	12122000007150	Water Collecting Cover	1
7	12222000004427	Chassis assembly	1
8	12222000A02011	Front panel	1
9	12122000A03621	Air Outlet Guard	1
10	12100105000057	Axial fan	1
11	11002015000041	Brushless DC Motor	1
12	12222000008924	Supporter assembly of fan motor	1
13	12222000001232	Left Side Floor	1
14	12222000003598	Top cover assembly	1
15	12222000004425	Partition board assembly	1
17	15422000004714	4-Ways valve assembly	1
17.1	15500204000021	Low Pressure Valve	1
17.2	15500216000028	4-way Valve	1
17.3	12222000002571	Installing plate for valves	1
18	15422000004973	Liquid valve assembly	1
18.1	15500208000028	Liquid valve	1
19	11103020000196	DC Inverter Rotary Compressor	1
20	11201007000005	Discharge temperature sensor assembly	1
21	17222000A44289	Electronic control box assembly	1
21.1	12222000001455	Electric Installing Box Cover	1
21.2	17122000A25350	Outdoor main control board assembly	1
21.3	12122000006913	Installation board for E-parts	1
21.5	12222000001311	Electric Installing Box Subassembly	1
22	15500406000010	Copper nut	1
22	15500406000016	Copper nut	1
25	12222000003986	Rear Net	1
31	12222000002259	Terminal Installing Plate	1
32	17400401000016	Wire holder	1
99	17401203000802	Connection cable assembly of compressor	1

EXPLODED VIEW AND SPARE PART LIST

11.9 Spare part list of model AWAU-YKD012-H11

No.	BOM Code	Part Name	Quantity
1	11201007002020	Room Temperature Sensor	1
2	15822000003296	Condenser Assembly	1
3	11201007000136	Pipe temperature sensor assembly	1
4	12222000003597	Parts fn Right Side Plate	1
5	12100701000015	Big handle	1
6	12122000007150	Water Collecting Cover	1
7	12222000004427	Chassis assembly	1
8	12222000A02011	Front panel	1
9	12122000A03621	Air Outlet Guard	1
10	12100105000057	Axial fan	1
11	11002015000041	Brushless DC Motor	1
12	12222000008924	Supporter assembly of fan motor	1
13	12222000001232	Left Side Floor	1
14	12222000003598	Top cover assembly	1
15	12222000004425	Partition board assembly	1
17	15422000004714	4-Ways valve assembly	1
17.1	15500204000021	Low Pressure Valve	1
17.2	15500216000028	4-way Valve	1
17.3	12222000002571	Installing plate for valves	1
18	15422000004973	Liquid valve assembly	1
18.1	15500208000028	Liquid valve	1
19	11103020000196	DC Inverter Rotary Compressor	1
20	11201007000005	Discharge temperature sensor assembly	1
21	17222000A44293	Electronic control box assembly	1
21.1	12222000001455	Electric Installing Box Cover	1
21.2	17122000A25352	Outdoor main control board assembly	1
21.3	12122000006913	Installation board for E-parts	1
21.5	12222000001311	Electric Installing Box Subassembly	1
22	15500406000010	Copper nut	1
22	15500406000016	Copper nut	1
25	12222000003986	Rear Net	1
31	12222000002259	Terminal Installing Plate	1
32	17400401000016	Wire holder	1
99	17401203000802	Connection cable assembly of compressor	1

11.10 Exploded view of model AWAU-YKD018-H11

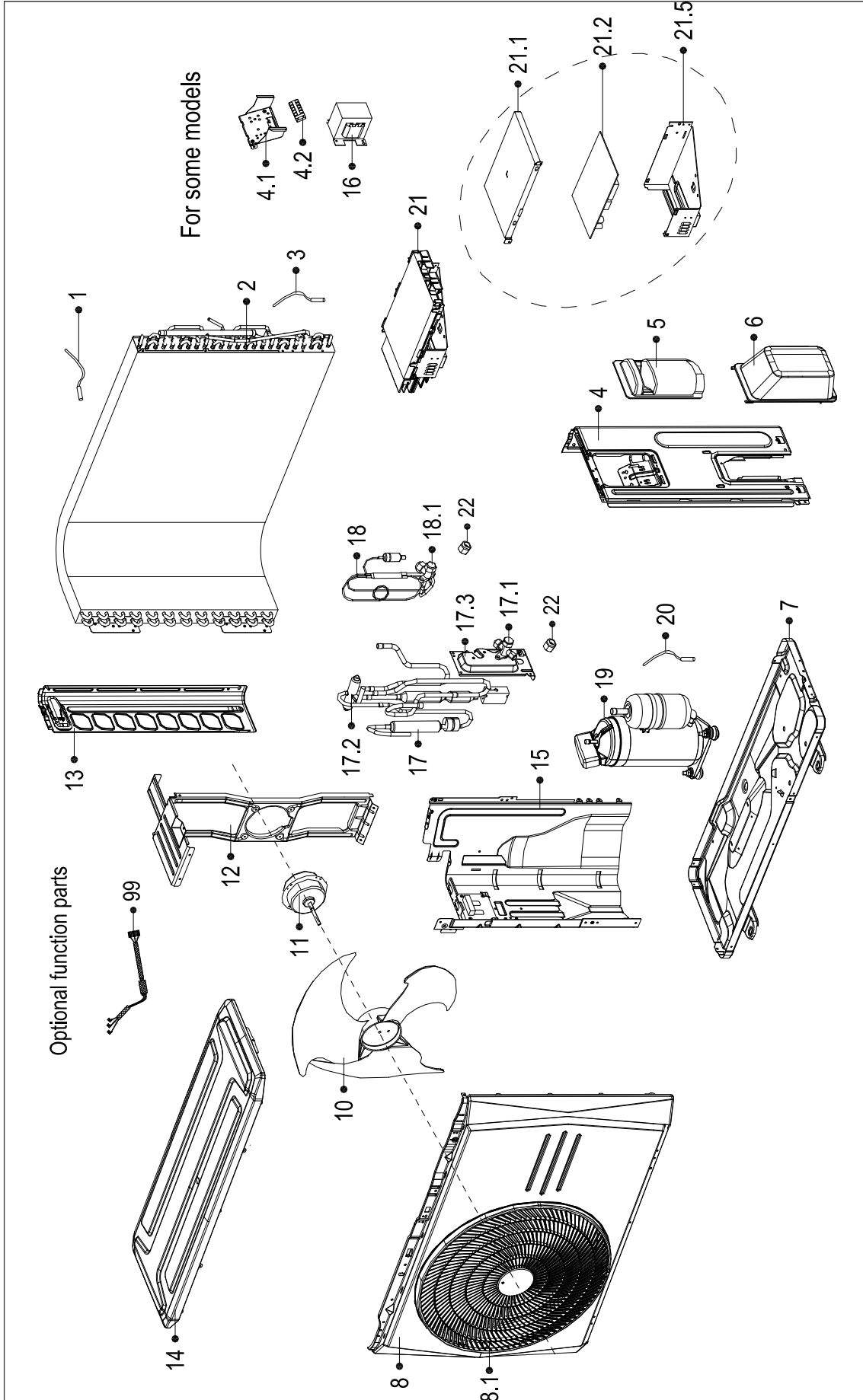

11.11 Spare part list of model: AWAU-YKD018-H11

No.	BOM Code	Part Name	Quantity
1	11201007002020	Room Temperature Sensor	1
2	15822000003682	Condenser Assembly	1
3	11201007000069	Pipe temperature sensor assembly	1
4	12222000004186	Right clapboard assembly	1
5	12100701000015	Big handle	1
6	12122000007150	Water Collecting Cover	1
7	12222000000711	Chassis Assembly	1
8	12222000A02014	Front panel	1
9	12122000A03621	Air Outlet Guard	1
10	12100105000051	Axial fan	1
11	11002015000041	Brushless DC Motor	1
12	12222200002154	Supporter assembly of fan motor	1
13	12222000008484	Left supporter	1
14	12222200001291	Top cover assembly	1
15	12222200001146	Separator Assembly	1
16	17400306000053	Reactor	1
17	15422000004716	Gas Valve Assembly	1
17.1	15500204000058	Low Pressure Valve	1
17.2	15500216000026	4-way Valve	1
17.3	12222000002571	Installing plate for valves	1
18	15422000004893	High-Voltage valve Assembly	1
18.1	15500208000028	Liquid valve	1
19	11103020000006	DC Inverter Rotary Compressor	1
20	11201007000005	Discharge temperature sensor assembly	1
21	17222000A44292	Electronic control box assembly	1
21.1	12122000006856	Electric Installing Box Subassembly	1
21.2	17122000A25347	Outdoor power board assembly	1
21.5	12222000001325	Electric Installing Box Subassembly	1
22	15500406000012	Copper nut	1
22	15500406000016	Copper nut	1
25	12222000003622	Rear Net	1
32	12222000002259	Terminal Installing Plate	1
33	17400401000016	Wire holder	1
99	17401203000802	Connection cable assembly of compressor	1

EXPLODED VIEW AND SPARE PART LIST

11.12 Exploded view of model: AWAU-YKD024-H11

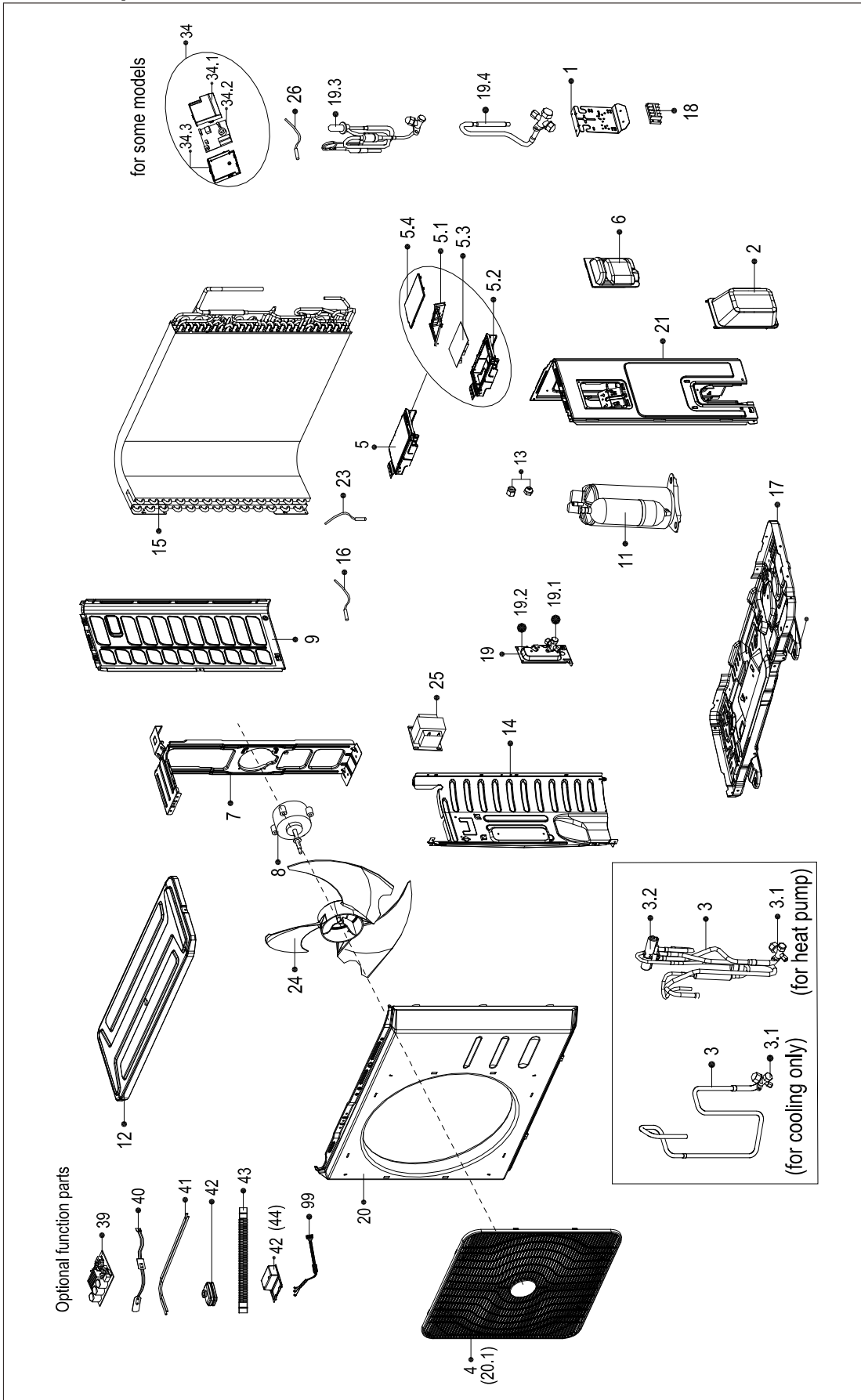

11.13 Spare part list of model: AWAU-YKD024-H11

No.	BOM Code	Part Name	Quantity
1	12222000004782	Terminal board	1
2	12122000007150	Water Collecting Cover	1
3	15422000004833	4-way valve assembly	1
3.1	15500204000025	Stop valve	1
3.2	15500216000026	4-way Valve	1
4	12122200A00490	Air Outlet Guard	1
5	17222000A44290	Electronic control box assembly	1
5.1	12122000014683	Supporting Plate	1
5.2	12222000004827	Cover of electronic control box	1
5.3	17122000A25353	Outdoor main control board assembly	1
5.4	12122000006856	Electric Installing Box Subassembly	1
6	12100701000015	Big handle	1
7	12222000004884	Supporter assembly of fan motor	1
8	11002015000397	Brushless DC Motor	1
9	12222000004794	Left side plate assembly	1
11	11103020000179	Inverter Controlled Rotary Compressor	1
12	12222000009205	Top cover assembly	1
13	15500406000003	Copper net	1
13	15500406000010	Copper nut	1
14	12222000004784	Partition board assembly	1
15	15822000004516	Condenser Assembly	1
16	11201007002020	Room Temperature Sensor	1
17	12222000004823	Chassis assembly	1
18	17400401000086	Wire holder	1
19	15422000004974	Liquid valve assembly	1
19.1	15500208000023	Liquid valve	1
19.2	12222000002571	Installing plate for valves	1
20	12222000004822	Front panel	1
21	12222000004785	Right side plate	1
23	11201007000069	Pipe temperature sensor assembly	1
24	12100105000181	Axial fan	1
25	17400306000058	Reactor	1
26	11201007000005	Discharge temperature sensor assembly	1
27	12222000004833	Rear net	1
99	17401203000939	Connection cable assembly of compressor	1

Airwell

SERVICE MANUAL

HKD DCI Series